

MILLING \ DRILLING MACHINE



MODEL 31(BS) / 31N2F(BS) / 25 INSTRUCTION MANUAL

31-100827-R4



WARNING !

Some dust created by power sanding, sawing, grinding, drilling, and other construction activities contains chemicals known to the State of California to cause cancer, birth defects or other reproductive harm. Some examples of these chemical are:

- Lead from lead-based paints.
- Crystalline silica from bricks, cement and other masonry products.
- Arsenic and chromium from chemically-treated lumber.

Your risk from these exposures varies, depending on how often you do this type of work. To reduce your exposure to these chemicals: Work in a well ventilated area, and work with approved safety equipment, such as those dust masks that are specially designed to filter out microscopic particles.

Table Of Contents

Page No

1 Overall Aspect	2
2 Safety Rules For tools	3
3 Specification	5
4 Features	6
5 Delivery & Installation	6
6 Minimum Room Space For Machine Operation	8
7 Use Of Main Machine Parts	8
8 Precaution For Operation	9
9 Adjusting Table Slack And Compensate For Wear	10
10 Clamping /Table Base And Machine Base	11
11 Speed Changing And Adjust Belt	11
12 To Change Tools	12
13 Ordering Replacement Parts	12
14 Extra Tooling And Accessories	12
15 Tapping Equipment	13
16 Spindle Power Down Feed Operation	13
17 Specification Of T Slot	14
18 Maintaining	14
19 Cleaning & Lubricating	14
20 Trouble Shooting	15
21 Circuit Diagram	18
22 Parts Lists	21

Overall Aspect

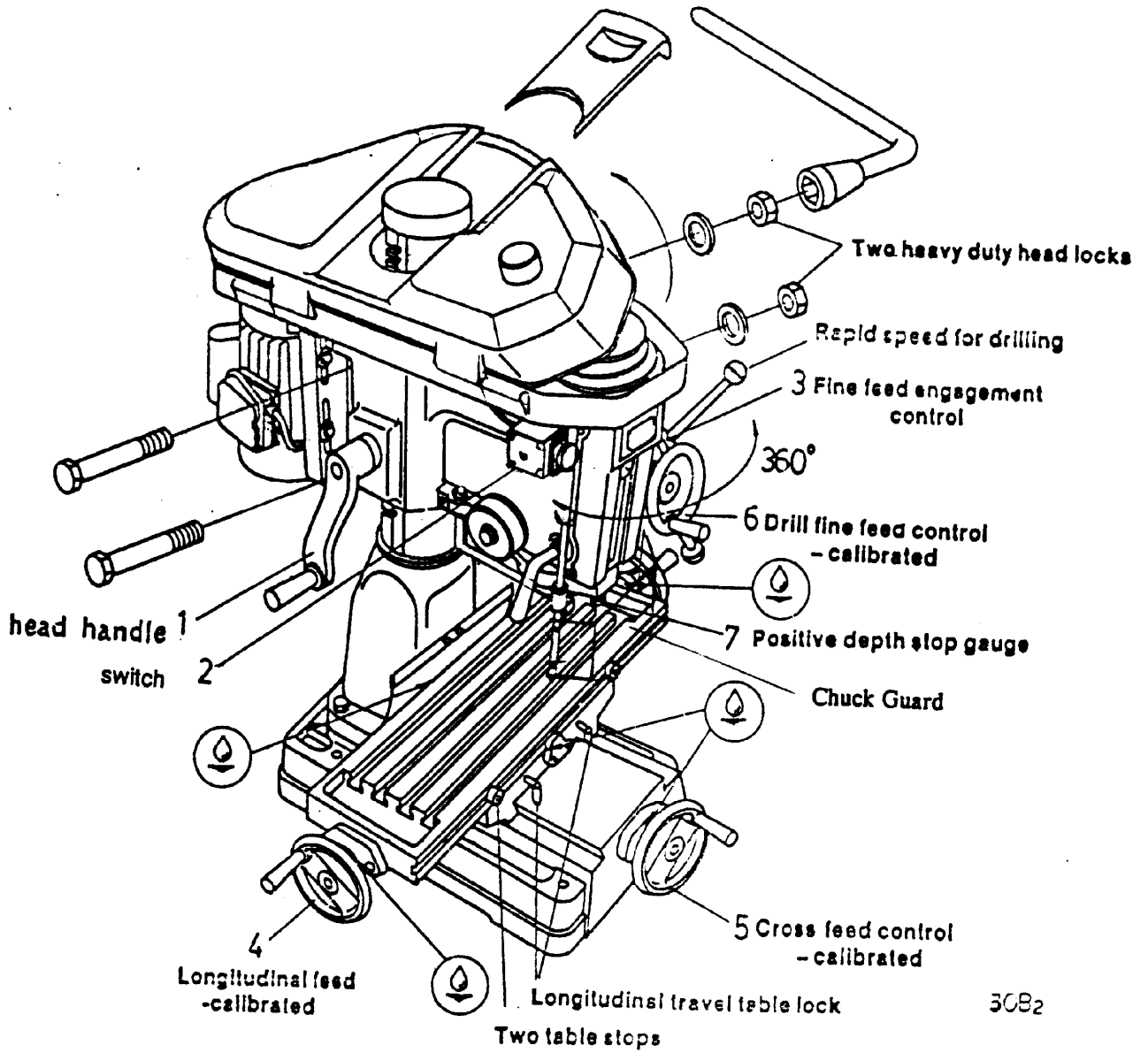

3082

Fig. 1

**WARNING: FAILURE TO FOLLOW THESE RULES
MAY RESULT IN SERIOUS PERSONAL INJURY**

As with all machinery there are certain hazards involved with operation and use of the machine. Using the machine with respect and caution will considerably lessen the possibility of personal injury. However, if normal safety precautions are overlooked or ignored, personal injury to the operator may result.

This machine was designed for certain applications only. We strongly recommends that this machine NOT be modified and/or used for any application other than for which it was designed. If you have any questions relative to its application DO NOT use the machine until you contact with us and we have advised you.

Your machine might not come with a power socket or plug. Before using this machine, please Do ask your local dealer to install the socket or plug on the power cable end.

SAFETY RULES FOR ALL TOOLS

A. USER:

1. **WEAR PROPER APPAREL.** No loose clothing, gloves, rings, bracelets, or other jewelry to get caught in moving parts.

Non-slip foot wear is recommended. Wear protective hair covering to contain long hair.

2. **ALWAYS WEAR EYE PROTECTION.** Refer to ANSLZ87.1 standard for appropriate recommendations.

Also use face or dust mask if cutting operation is dusty.

3. **DON'T OVERREACH.** Keep proper footing and balance at all times.

4. **NEVER STAND ON TOOL.** Serious injury could occur if the tool is tipped or if the cutting tool is accidentally contacted.

5. **NEVER LEAVE TOOL RUNNING UNATTENDED. TURN POWER OFF.** Don't leave tool until it comes to a complete stop.

6. **DRUGS, ALCOHOL, MEDICATION.** Do not operate tool while under the influence of drug, alcohol or any medication.

B. USE OF MACHINE:

1. **DON'T FORCE TOOL.** It will do the job better and be safer at the rate for which it was designed.

2. **USE RIGHT TOOL.** Don't force tool or attachment to do a job for which it was not designed.

3. **SECURE WORK.** Use clamps or a vise to hold work when practical. It's safer than using your

hand frees both hands to operate tool.

4. **USE RECOMMENDED ACCESSORIES.** Consult the owner's manual for recommended accessories. The use of improper accessories may cause hazards.

5. **AVOID ACCIDENTAL STARTING.** Make sure switch is in “**OFF**” position before plugging in power cord.

C. ADJUSTMENT :

MAKE all adjustments with the power off. In order to obtain the machine. precision and correct ways of adjustment while assembling, the user should read the detailed instruction in this manual.

D. WORKING ENVIRONMENT:

1. **KEEP WORK AREA CLEAN.** Cluttered areas and benches invite accidents.

2. **DON'T USE IN DANGEROUS ENVIRONMENT.** Don't use power tools in damp or wet locations, or expose them to rain. Keep work area well-lighted.

3. **KEEP CHILDREN AND VISITORS AWAY.** All children and visitors should be kept a safe distance from work area.

4. **DON'T** install & use this machine in explosive, dangerous environment.

E. MAINTENANCE

1. **DISCONNECT** machine from power source when making repairs.

2. **CHECK DAMAGED PARTS.** To read every details of trouble shooting, repair it very carefully and make sure the operator won't get injure and damage the machine.

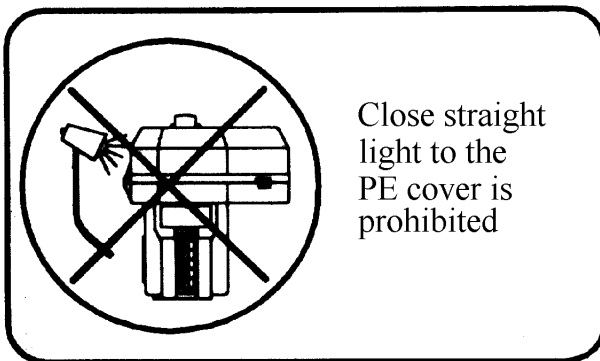

Thank you for purchasing the **31 MILLING/GRILLING** Machine. If properly cared for and operated, this machine can provide you with years of accurate service. Please read this manual carefully before using your machine.

1.SPECIFICATION

MODEL			31(BS) / 31N2F(BS)	25
Drilling capacity			32mm(1 ¹ / ₄ ")	25 mm (1")
Face mill capacity			76mm(3")	64 mm (2-1/2")
End mill capacity			20mm(3/4")	13mm (1/2")
Spindle nose to column surface			170mm(6-3/4")	170mm(6-3/4")
Max. distance spindle nose to table			430mm(16-7/8")	325 mm(12-3/4")
Spindle taper			M.T.3 R-8	M.T.3 R-8
Spindle stroke			130mm(5-1/8")(N2F=107mm)	90 mm (3-1/2")
Diameter of Spindle sleeve			75mm(3")	62 mm (2-7/16")
Head swivel			360°	360°
Diameter of column			115mm(4-1/2")	92 mm (3-5/8")
Overall height (w/o stand)			1240mm(48-7/8")	1050 mm (41-3/8")
Length			990mm(39")	910mm(35-7/8")
Width			1100mm(43-3/8")	960mm(37-7/8")
Machine stand height			715mm(28-1/8")	715mm(28-1/8")
Motor			1-1/2HP - 2HP	3/4HP – 1HP
Spindle speed (r.p.m.)	12S	50Hz	125-2500	90-2150
		60Hz	150-3000	110-2580
Standard accessories			3"-cutter 1/2" chuck 3 " angle vise	2 1/2" –cutter 1/2" chuck 3" angle vise
Forward and backward travel of table			185mm(7-1/4")	150 mm (5-7/8")
Right and left travel of table			430mm(16-7/8")	340 mm (13-3/8")
Working area of table			730mm x 210mm(28 ³ / ₄ "x 8 ¹ / ₄ ")	585mm x 190mm(23"x 7 ¹ / ₂ ")
Gross weight			300kgs (660 lbs)	200kgs (440 lbs)
Measurement			20' Container Q'ty: 42 sets	20' Container Q'ty: 48 sets
Extra accessories			Power down (spindle) feed Tapping switch Forward & Reverse switch Collet chuck Work light Cabinet stand Extension column Clamping kits	Forward & Reverse switch Collet chuck Work light Cabinet stand Clamping kits
Noise			80 dB MAX	80 dB MAX

Tools selection & proper material range

Tool type	Tool material	Work piece material
End mill	HSS	Non-iron material steel iron
	TUNGSTEN CARBIDE	Cast iron non-iron material
Face mill	TUNGSTEN CARBIDE	Non-iron material steel iron Light material
Drilling	HSS	Non-iron material steel iron Light material
Tapping	HSS	Non-iron material steel iron Light material

2. FEATURES

- (1) This machine has, several uses, such as surface cutting, drilling, milling, and also can be equipped with an electric switch for tapping.
- (2) This machine is of fine quality, can be operated easily, and it is not limited to skilled operators.
- (3) The drilling and milling operation can be performed by two methods:
 - 1). Hand operation, which makes quick drilling.
 - 2). Worm gear feed operation, which makes slow milling.
- (4) Bronze adjustable nuts, which adjust the thread clearance and reduce the wear. They also make screws rotated smoothly and increase the thread accuracy.
- (5) Whole column which makes this machine strong, stable, and also keep the high accuracy.
- (6) Head of tough cast ensures its accuracy lasting and enduring through the treatment of precise boring cylinder, grinding, and internal stress relief.
- (7) To adjust belt and change speed, new pulley cover is easy to open the cover.

3. DELIVERY & INSTALLATION

Unpacking

1. Transportation to desired location before unpacking, please use lifting jack.(Fig. B)
2. Transportation after unpacking, please use heavy duty fiber belt to lift up the machine.

ALLWAYS KEEP PROPER FOOTING & BALANCE WHILE MOVING THIS MACHINE.

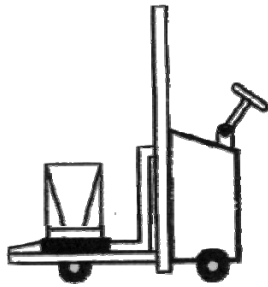
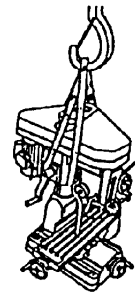

Fig. B

Installation:

- (1) **BE SURE** all locks of head-stock & column are tighten before operation.
- (2) **ALWAYS** Keep proper footing & balance while moving this 300kgs machine. And only use heavy duty fiber belt to lift the machine as per Fig. A.
- (3) **KEEP** machine always out from sun, dust, wet, raining area.
- (4) **POSITION** & tighten 4 bolts into base holes properly after machine in balance.
- (5) **TURN OFF** the power before wiring & be sure machine in proper grounding. Overload & circuit breaker is recommended safety wiring.
- (6) **CHECK** carefully if main shaft in clockwise direction while running test. If not, reverse the wiring then, repeat the test till spindle direction is correct.
- (7) **Finish** removing this wooden case/crate from the machine.
Unbolt the machine from the crate bottom.
- (8) **Carefully** lift the machine to a sturdy stand or work bench. For best performance, through bolt the machine to bench or stand.
- (9) **Bolt** the stand legs to the floor, while using a sturdy stand.



for

Fig. A

Fig. A

Before Bolting The Machine To A Bench Or Stand Or Floor, The Unit Must Be Level In Both Directions.

4. MINIMUM ROOM SPACE FOR MACHINE OPERATION

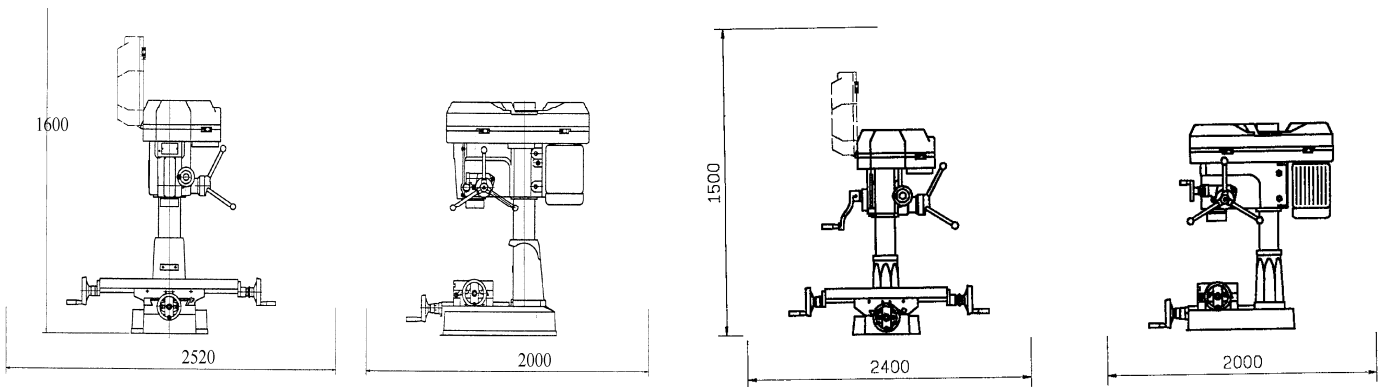

For 31/31N2F

For 25

5. USE OF MAIN MACHINE PARTS (See Fig. 1)

- (1) To raise and lower the head by head handle.
- (2) Equipped with an electric switch for tapping operation clockwise or counterclockwise.
- (3) To adjust the quick or slow feeding by feed handle.
- (4) To adjust the table left and right travel by table handle wheel.
- (5) To adjust the table fore and aft travel by table handle wheel.
- (6) To operate the spindle handle wheel for micro feed.
- (7) To adjust the scale size according to working need.
- (8) Switch button function description.

- (a) Before starting the machine turn the selection knob (A) to (right for clock wise running, left for counter clock vise)
- (b) Push button (C) to start the machine.
- (c) Push button (B) to stop the machine.
- (d) When in emergency push button to stop the machine. after clearing the trouble, release emergency button, re-start the machine by pushing the start button.

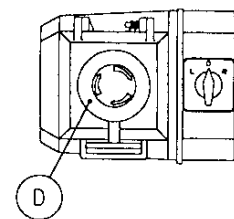
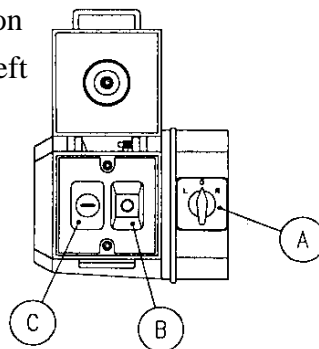

6. PRECAUTION FOR OPERATION

Check all parts for proper condition before operation; if normal safety precautions are notice carefully, this machine can provide you withstanding of accurate service.

(1) Before Operation

- (a) Fill the lubricant.
- (b) In order to keep the accurate precision, the table must be free from dust and oil deposits.
- (c) Check to see that the tools are correctly set and the work-piece is set firmly.
- (d) Be sure the speed is not set too fast.
- (e) Be sure everything is ready before use.

(2) After Operation

- (a) Turn off the electric switch.
- (b) Turn down the tools.
- (c) Clean the machine and coat it with lubricant.
- (d) Cover the machine with cloth to keep out the dust.

(3) Adjustment of Head

- (a) To raise and lower the head, loosen the two heavy duty head lock nuts shown in Fig.1. Use the left side head handle to raise and lower the head on its rack and pinion mechanism. When the desired height is reached, tighten the bolts to avoid vibration.
- (b) Head may be rotated 360° by loosening the same bolts mentioned above. Adjust the head to the desired angle, then fix the heavy duty head lock-nuts. It is tighten the same time to fix the head if drilling & milling too much.

(4) Preparing for Drilling (see fig. 2)(Except addition power feed system).

Turn of the knob make loose the taper body of worm gear and spring base. Then we decide spindle stroke setting the positive depth stop gauge for drilling blind hole or free state for pass hole.

(5) Preparing for Milling (see fig. 2)(Except addition power feed system).

- (a) Adjust the positive depth stop gauge to highest point position.
- (b) Turn tight of the knob be use to taper friction force coupling the worm gear and spring base.
Then turning the handle wheel by micro set the spindle of work piece machining height.
- (c) Lock the rack sleeve at the desired height with fixed bolt.

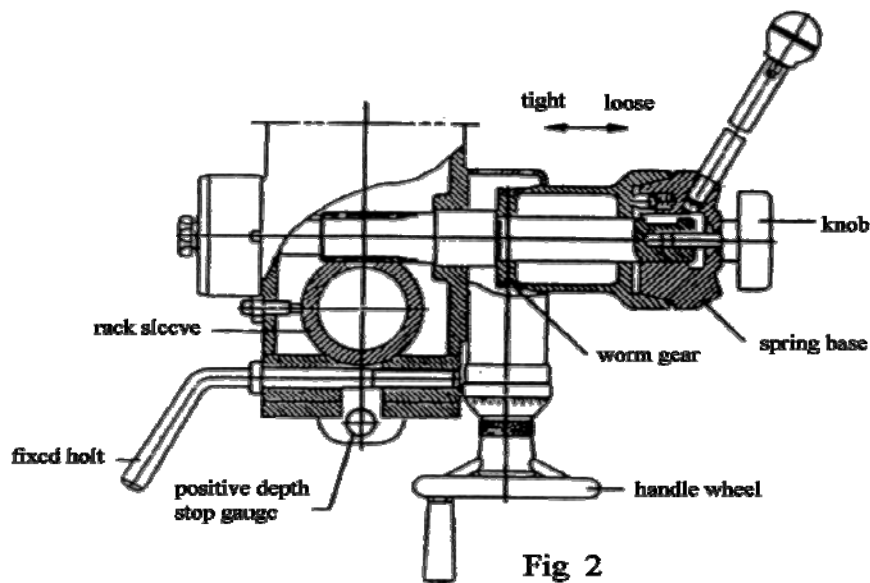

Fig 2

QUILL RETURN SPRING ADJUSTMENT:

Spring tension for return of spindle, after hole drilling, has been pre-set at the factory. No further adjustment should be attempted unless absolutely necessary. Adjustment will probably be required if a multiple drilling or tapping head is used. If adjustment is necessary, loosen lock screw while holding. Do not allow the housing to turn in your hand, or spring will unwind. Turn entire housing assembly clockwise the number of turns necessary to cause the quill to return to its up position. (NOTE. The flat of the spring housing pilot is lined up with the spring loading hole on the body of the spring housing.) Reset lock screw make sure point of screw mates to flat on the housing journal.

7. ADJUSTING TABLE SLACK AND COMPENSATE FOR WEAR (see Fig. 3)

- (1) Your machine is equipped with Jib strip adjustment to compensate for wear and excess slack on cross and longitudinal travel.
- (2) Clockwise rotation the job strip bolt with a big screw for excess slack otherwise a little counter clockwise if too tight.
- (3) Adjust the jib strip bolt until feel a slight drag when shifting the table.

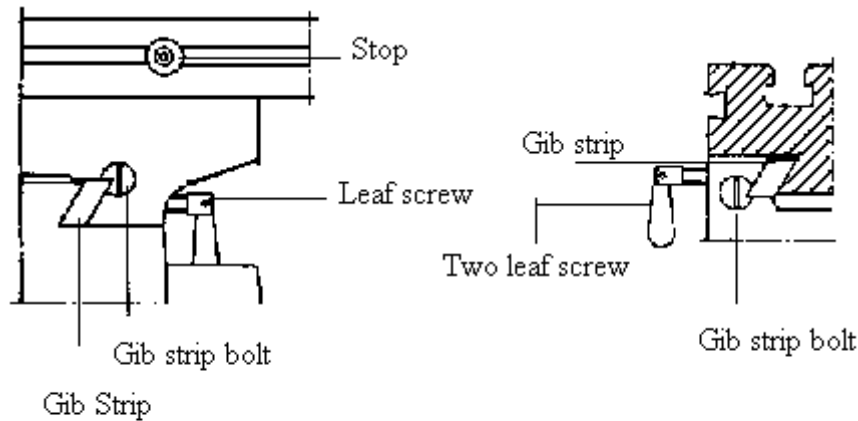

Fig. 3.

8. CLAMPING, TABLE BASE, AND MACHINE BASE (see Fig. 3)

- (1) When milling longitudinal feed, it is advisable to lock the cross feed table travel to insure the accuracy of your work. To do this, tighten the small leaf screw located on the right side of the table base.
- (2) To tighten the longitudinal feed travel of the table for cross feed milling, tighten the two small leaf screw on the front of the table base
- (3) Adjustable travel stops are provided on the front of the table for control of cross travel and the desired milling length.

9. SPEED CHANGING AND ADJUST BELT (Step See Fig. 4)

- (1) Turn power off.
- (2) Open belt cover by releasing side latches step see(a)(b)(c).
- (3) Loosen motor mount leaf screw.
- (4) Push motor in order to loosen belts(head side of motor mount is set fixed, two motor's ear side with motor screw to tighten or loosen of belts.)
- (5) Loosen two screws for base of speed change inter pulley that also adjust the location of base for speed change inter pulley.
- (6) Select the suitable R.P.M. from speed charts of table 1. Then place the belts on the desired pulley steps.
- (7) Tighten two screws of base for speed change pulley and the bolt of motor mount lock.
- (8) Cover the belt cover before turning power on.

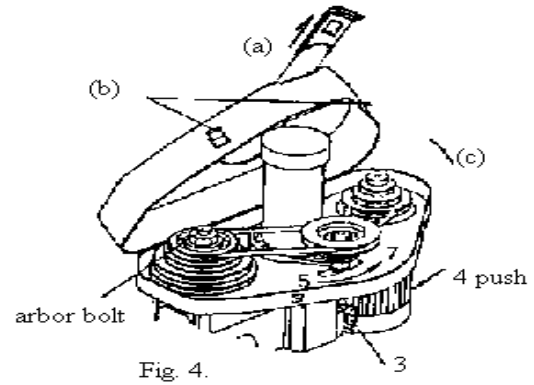

12 SPEEDS		BELT	12 SPEEDS		BELT
50Hz	60Hz		50Hz	60Hz	
125	150	4-5	710	850	1-6
185	225	3-5	1000	1200	2-7
210	255	4-6	1250	1500	3-8
300	350	2-5	1350	1600	1-7
350	400	3-6	1900	2300	2-8
420	500	4-7	2500	3000	1-8

Table .1 For 31/31N2F

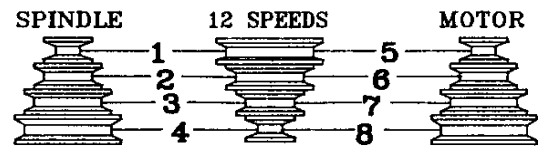

50ℓ	60ℓ	COURROIE	50ℓ	60ℓ	COURROIE
90	110	4-5	600	730	1-6
170	210	4-6	700	850	2-7
200	240	3-5	950	1140	1-7
250	300	2-5	1290	1550	3-8
280	340	4-7	1590	1910	2-8
360	440	3-6	2150	2580	1-8

For 25

10. TO CHANGE TOOLS

(1) Removing Face Mill or Drill Chuck Arbor

Loosen the arbor bolt (see fig. 4) at the top of the spindle shaft approximately 2 turns with a wrench. Rap the top of the arbor bolt with a mallet. After taper has been broken loose, holding chuck arbor on hand and turn detach the arbor bolt with the other hand.

(2) To Install Face Mill or Cutter Arbor

Insert cutter and cutter arbor into the taper of spindle. Tighten arbor bolt detach securely, but do not over-tighten.

(3) Removing Taper Drills

(a) Turn down the arbor bolt and insert the taper drill into the spindle shaft.

(b) Turn the rapid down handle rod down until the oblong hole in the rack sleeve appears.

Line up this hole with the hole in the spindle. Insert key punch key through holes and strike lightly with a mallet. This will force the taper drill out.

11. ORDERING REPLACEMENT PARTS

Complete parts list is attached. If parts are needed, contact your local distributor.

12. EXTRA TOOLING AND ACCESSORIES

Each of machines is equipped with a MT # 3 spindle taper or a R-8 spindle taper (examples below). Contact your local distributor or a major cutting tool distributor to obtain any of these accessories.

Taper Drills

Reamers

End Mills
Cutter Arbor
Taps
Collets
Adapters and Sleeves

13. TAPPING EQUIPMENT

This machine can be equipped with an electric switch for tapping operation clockwise or counter-clockwise, and the working depth also can be adjusted by the limit switch. (Electric switch will be installed according to your requirement, and you must pay the cost only.)

14. SPINDLE POWER DOWN FEED OPERATION

1. Select profitable spindle speed and automatic feeding rate according to cutting condition.

By adjusting the shift dial A you can obtain the feed rate you need.

2. **FEEDING DEPTH SETTING:**

First release the dial fix-nut E and turn the indicating ring C to the depth needed. then reset E tightly again.

CAUTION: DO NOT LET FEEDING DEPTH EXCEED SPINDLE STROKE.

3. **START FEEDING**

Start the machine and push out the handle rod D, then the spindle will feed down automatically until the end of stroke you set.

4. **END OF AUTO FEEDING**

The spindle will return to top when reaching the end of stroke you set. when in emergency or Desire to stop the motion during feeding, push back the handle rod D to its original place.

5. **MICRO FEEDING BY MANUAL**

Set the shift dial A to "0" position, and start feeding by turning F handle.

6. To prevent danger, when spindle power down feed is not in use, please lock the handle B well.

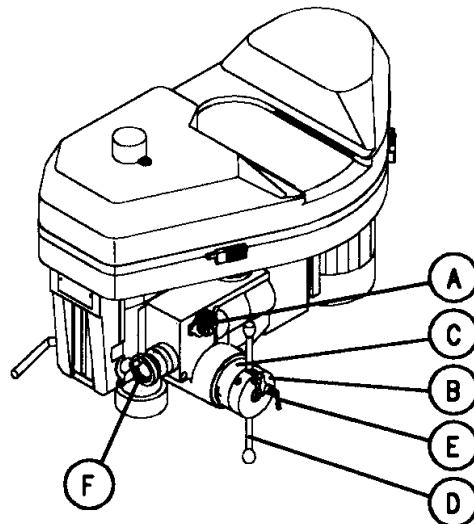

15. SPECIFICATION OF T-SOLT

The size of T-Solt on table as Fig 6:

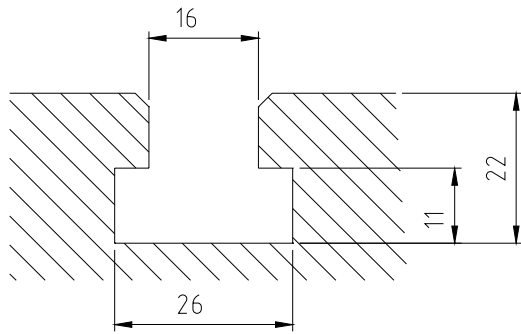

For 31/31N2F

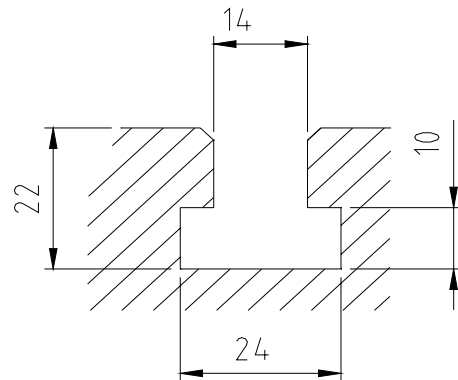

For 25

16. MAINTAINING

That's easier to keep machine in good condition or best performance by means of maintaining it at any time than remedy it after it is out of order.

(1) Daily Maintenance (by operator)

- (a) Fill the lubricant before starting machine everyday.
- (b) If the temperature of spindle caused over-heating or strange noise, stop machine immediately to check it for keeping accurate performance.
- (c) Keep work area clean; release vise, cutter, work-piece from table; switch off power source; take chip or dust away from machine and follow instructions lubrication or coating rust proof oil before leaving.

(2) Weekly Maintenance

- (a) Clean and coat the cross leading screw with oil.
- (b) Check to see if sliding surface and turning parts lack of lubricant. If the lubricant is insufficient, fill it.

(3) Monthly Maintenance

- (a) Adjust the accurate gap of slide both on cross and longitudinal feed.
- (b) Lubricate bearing, worm, and worm shaft to avoid wear.

(4) Yearly Maintenance

- (a) Adjust table to horizontal position for maintenance of accuracy.
- (b) Check electric cord, plugs, switches at least once a year to avoid loosening or wearing.

17. CLEANING & LUBRICATING

- (1) Your machine has been coated with a heavy grease to protect it in shipping. This coating should be completely removed before operating the machine. Commercial degreaser, kerosene or similar solvent may be used to remove the grease from the machine, but avoid getting solvent

on belts or other rubber parts.

- (2) After cleaning, coat all possible rusted surface with a light lubricant. Lubricate all points in Fig.1. with a medium consistency machine oil.
- (4) Lubricating points as shown in arrows.

18. TROUBLE SHOOTING

(1) No running after switch on:

- (a) Main switch interruption while volts irregular - Adjust input voltage and draw back the main switch.
- (b) Break down of fuse in switch box - Replace with new one.
- (c) In case of too much current, the overload relay jumps away automatically - Press the overload relay, and it will return to the correct position.

(2) Motor Overheat and No Power:

- (a) Overload - Decrease the load of feed.
- (b) Lower voltage - Adjust to accurate voltage.
- (c) Spoiled contact point of magnetic switch - Replace with new one.
- (d) Breakdown of overload relay - Connect it or replace with new one.
- (e) Motor is poor - Replace with new one.
- (f) Break down of fuse or poor contact with wire (it is easily, to spoil motor while short circuit)
Switch off power source at once and replace fuse with new one.
- (g) The tension of pulley V-belt too tight - Adjust for proper tension of V-belt.
- (h) If this machine with the tapping attachment, there is an aid plum screw fix on the motor mount in order to avoid the motor pulleys shake while turning.

(3) The temperature of spindle bearing is too hot:

- (a) Grease is insufficient - Fill the grease.
- (b) The spindle beating is fixed too tight - turning with no speed and feel the tightness with hand.
- (c) Turning with high speed for a long time - Turn it to lightly cutting.

(4) Lack of power with main spindle revolving:

- (a) The tension of V-belt too loose - Adjust for proper tension of V-belt.
- (b) Motor has burned out - Change a new motor.
- (c) Fuse has burned out - Replace with new one.

(5) Table travel has not balanced:

- (a) The gap of spindle taper too wide - Adjust bolt in proper.
- (b) Loosening of leaf bolt - Turn and fasten in place.
- (c) Feed too deep -Decrease depth of feed.

(6) Shake of spindle and roughness of working surface has taken place during performance:

- (a) The gap of spindle bearing too wide - Adjust the gap in proper or replace bearing with new one.

- (b) Spindle loosening up and down - Make two of inner bearing covers on the top tight each other. Do not over-tighten two inner bearing covers with the taper bearing; it is ok as long as no gap between them.
 - (c) The gap of taper sliding locate too wide - Adjust the tension of bolt in proper.
 - (d) Loosening of chuck - Fasten chuck.
 - (e) Cutter is dull – Re-sharpen it.
 - (f) Work-piece has not hold firmly - Be sure to tighten work-piece.
- (7) Micro feed does not work smoothly:
- (a) Loosening of clutch - Be sure to tighten it.
 - (b) Worm and worm shaft has worried out - Replace with new one.
 - (c) Loosening of hand-wheel fixed screw - Be sure to tighten it.
- (8) Without accuracy in performance:
- (a) The balance of the work-piece - must be considerate as the principle balance while holding work-piece.
 - (b) Often use of hammer to strike work-piece - Forbidden to use hammer to strike work-piece.
 - (c) Unaccurate horizontal table - Check and maintain table for keeping accurate horizontal after a period of use.
- (9) Excessive vibration:
- (a) Motor out-of-balance. – Balance or replace problem motor.
 - (b) Bad motor. – Replace motor.
- (10) Motor stalls:
- (a) Over feeding - Reduce feed rate.
 - (b) Dull drill – Sharpen drill and keep sharp.
 - (c) Motor not building up to running speed. – Replace or repair motor. Check fuses in all three legs on three phase motors and replace if necessary.
 - (d) Bad motor. – Replace motor.
- (11) Noisy operation:
- (a) Excessive vibration. – Check remedy under excessive vibration.
 - (b) Improper quill adjustment. – Adjust quill.
 - (c) Noisy spindle. – Lubricate spindle.
 - (d) Noisy motor. – Check motor bearings or for loose motor fan.
- (12) Drill or Tool heats up or burns work:
- (a) Excessive speed. – Reduce speed.
 - (b) Chips not clearing. – Use pecking operation to clear chips.
 - (c) Dull tool. – Sharpen tool or replace.
 - (d) Feed rate too slow. – Increase feed enough to clear chips.
 - (e) Rotation of frill incorrect. – Reverse motor rotation.
 - (f) Failure to use cutting oil or coolant (on steel). – Use cutting oil or coolant on steel.

(13) Drill leads off:

- (a) No drill spot. – Center punch or center drill work-piece.
- (b) Cutting lips on drill off center. – Regrind drill.
- (c) Quill loose in head. – Tighten quill.
- (d) Bearing play. – Check bearings and reseat or replace if necessary.

(14) Excessive drill run-out or wobble:

- (a) Bent drill. – Replace drill. Do not attempt to straighten.
- (b) Bearing play. – Replace or reseat bearings.
- (c) Drill not seated properly in chucks. – Loosen, reseat and tighten chuck.

(15) Work or fixture comes loose or spins:

Failure to clamp work-piece or work holding device to table. – Clamp work-piece or work holding device to table surface.

CIRCUIT DIAGRAM

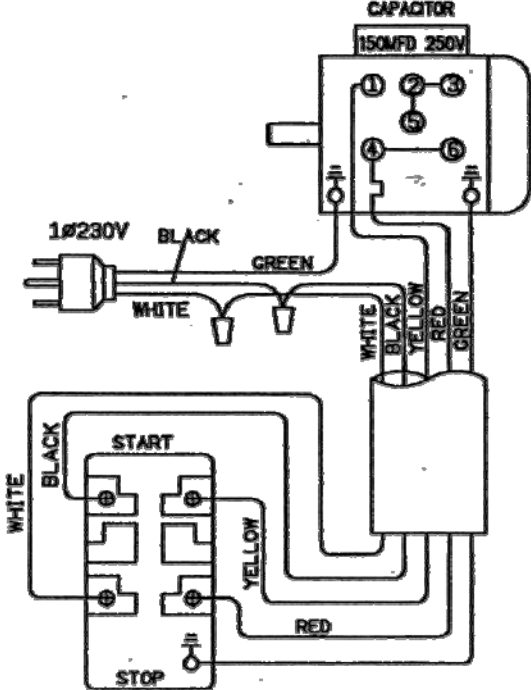
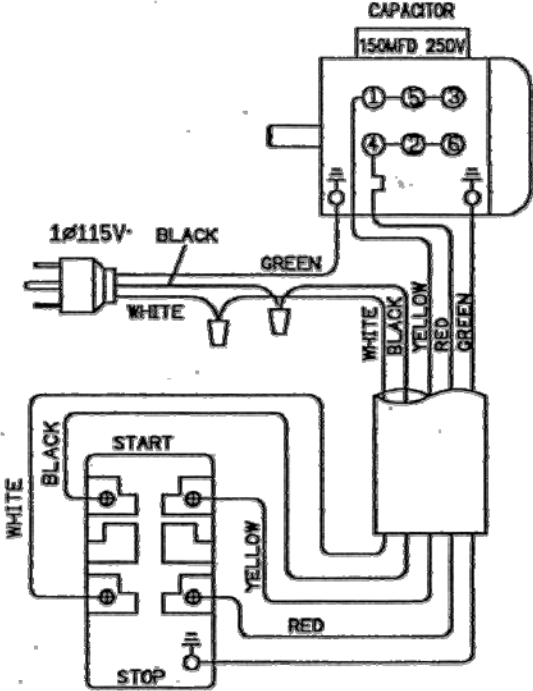

CIRCUIT DIAGRAM

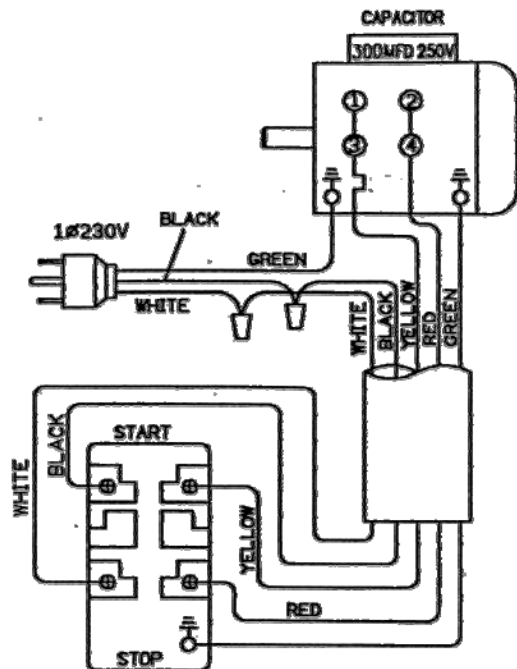

220V

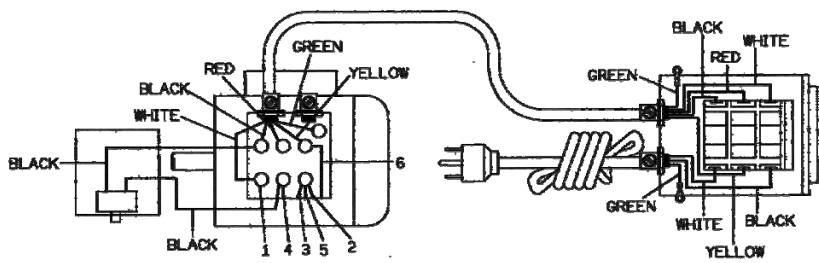

110V

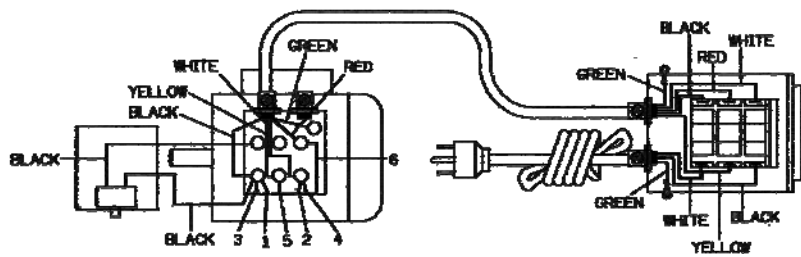

CIRCUIT DIAGRAM

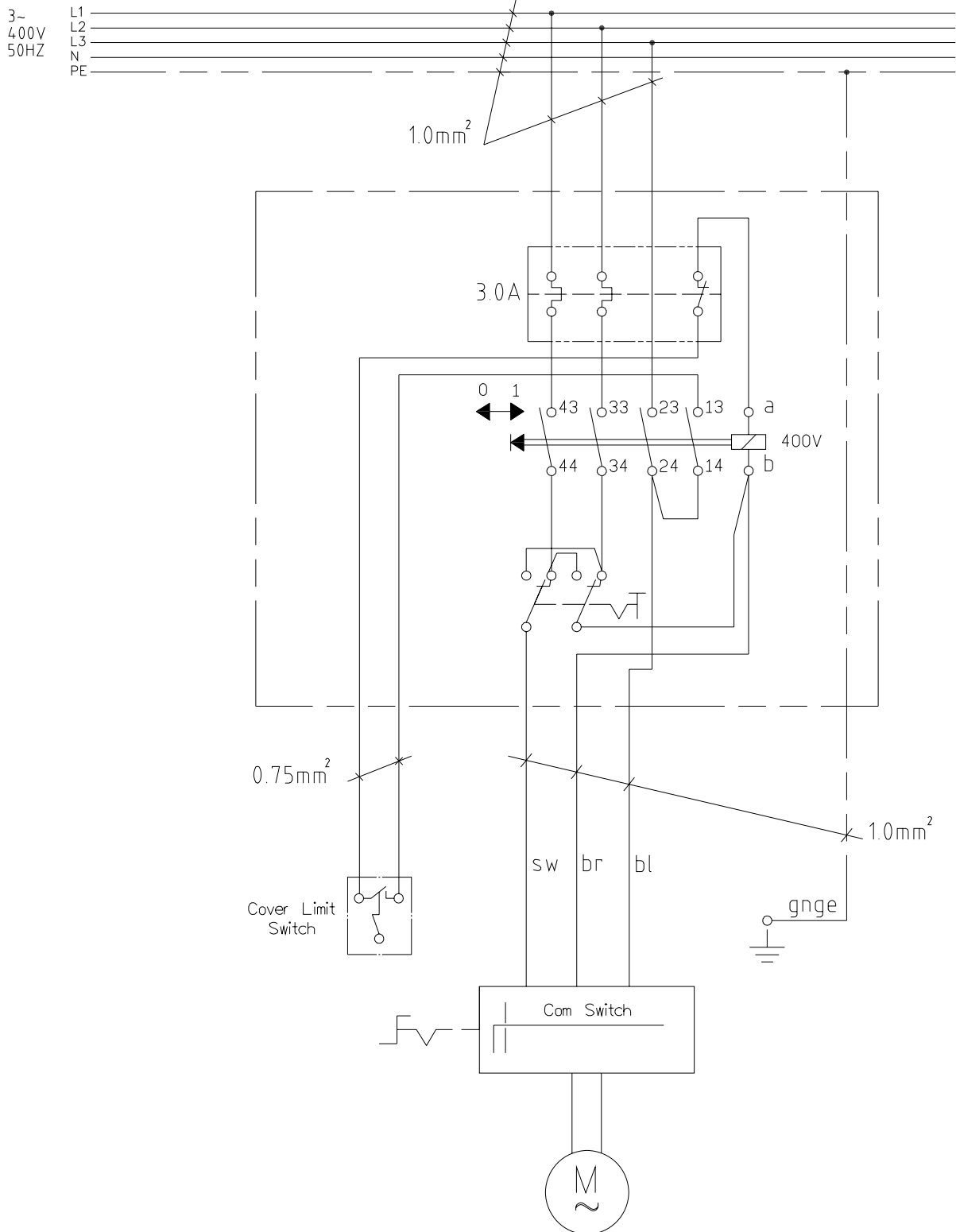

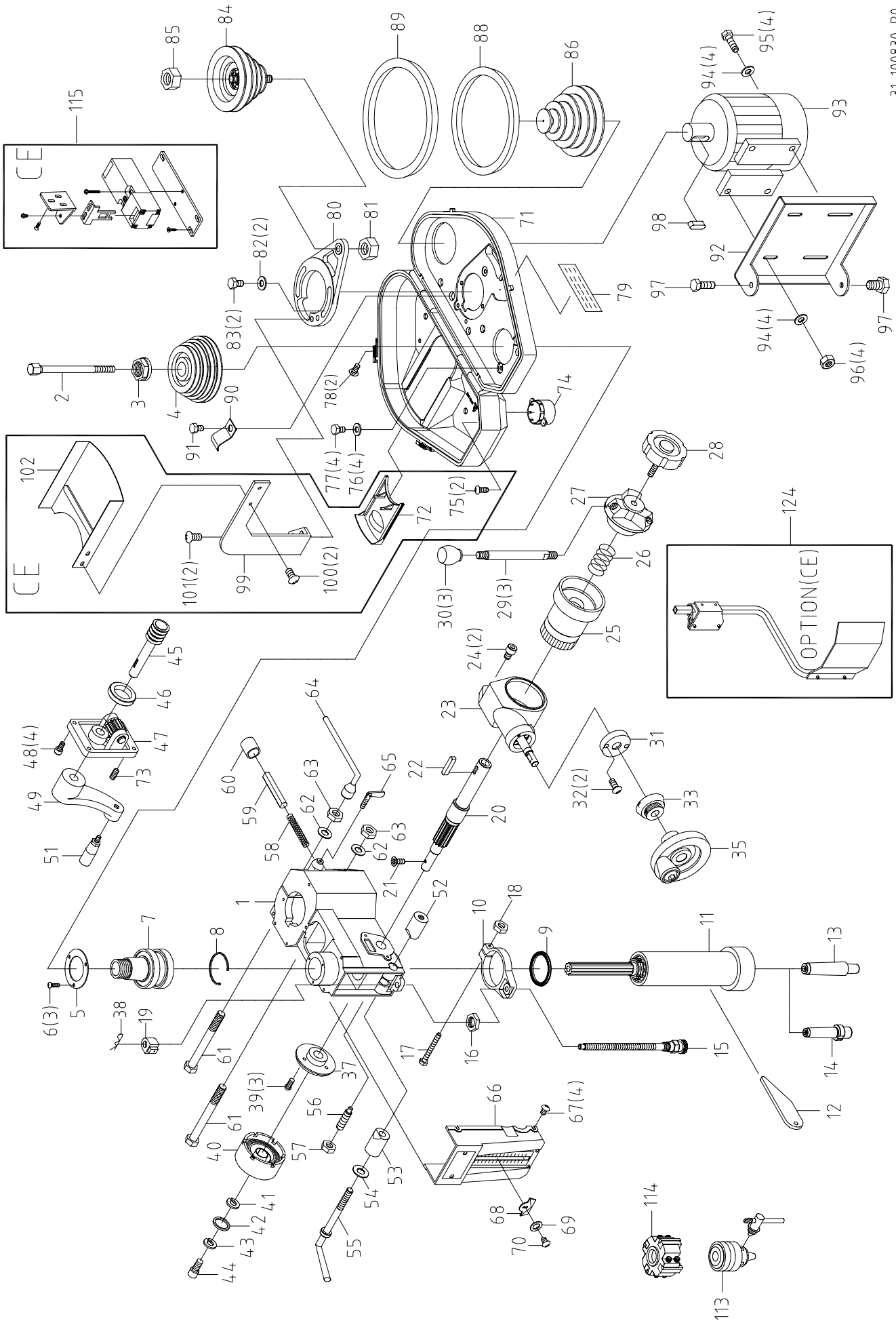

31-100830-R0

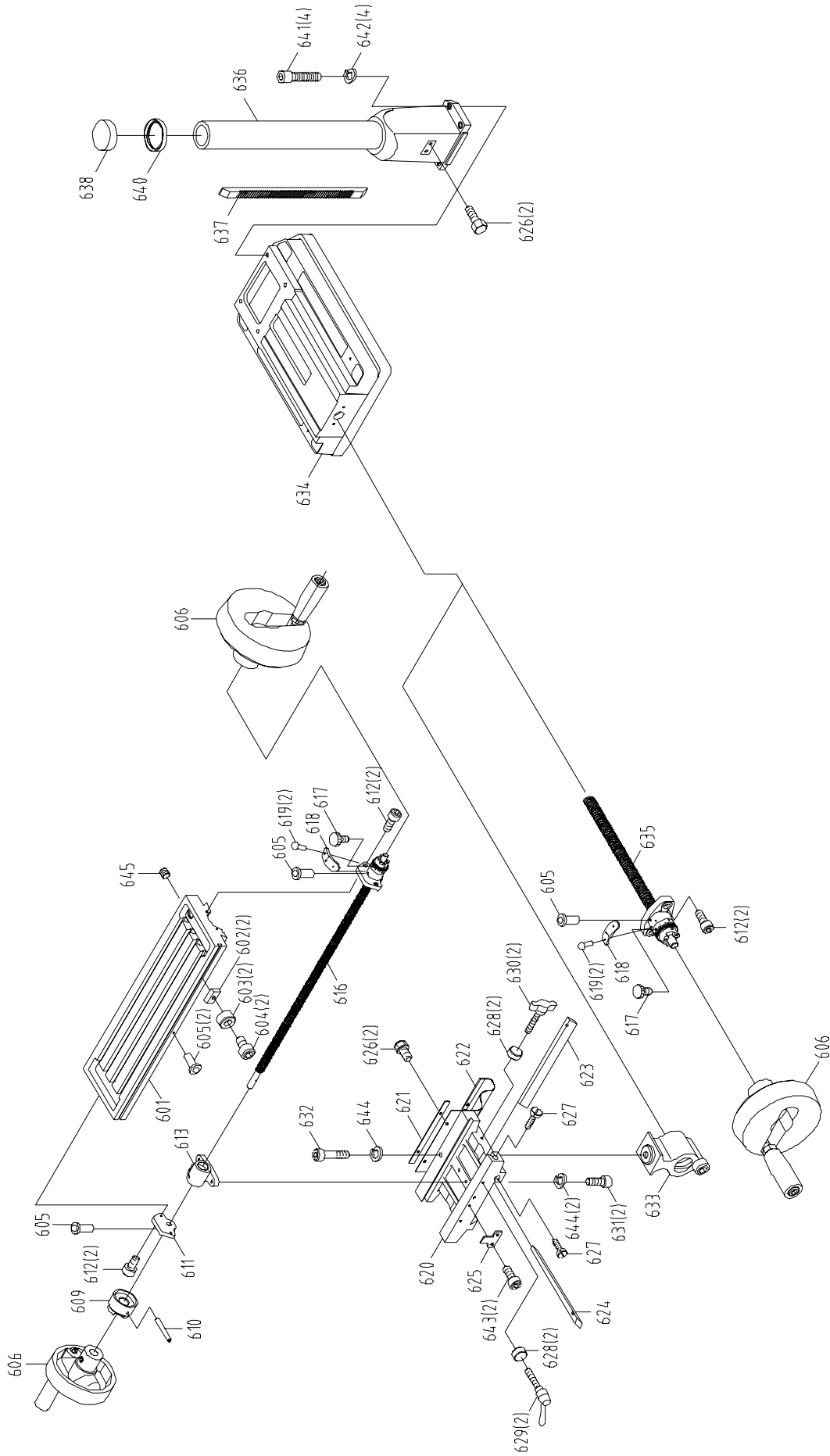

31TA

2006.07.20

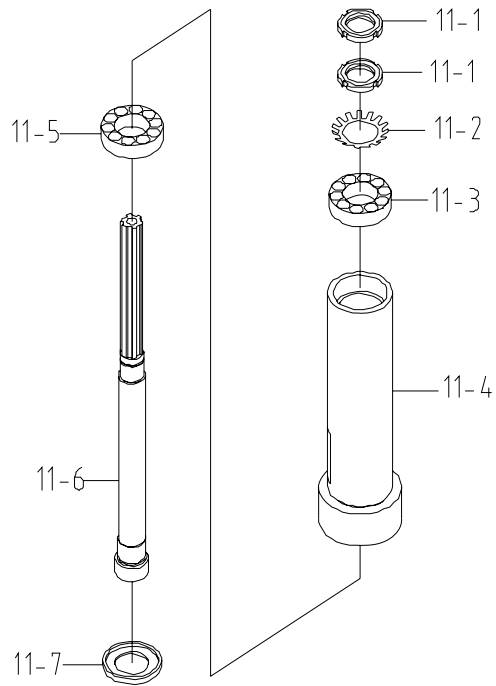
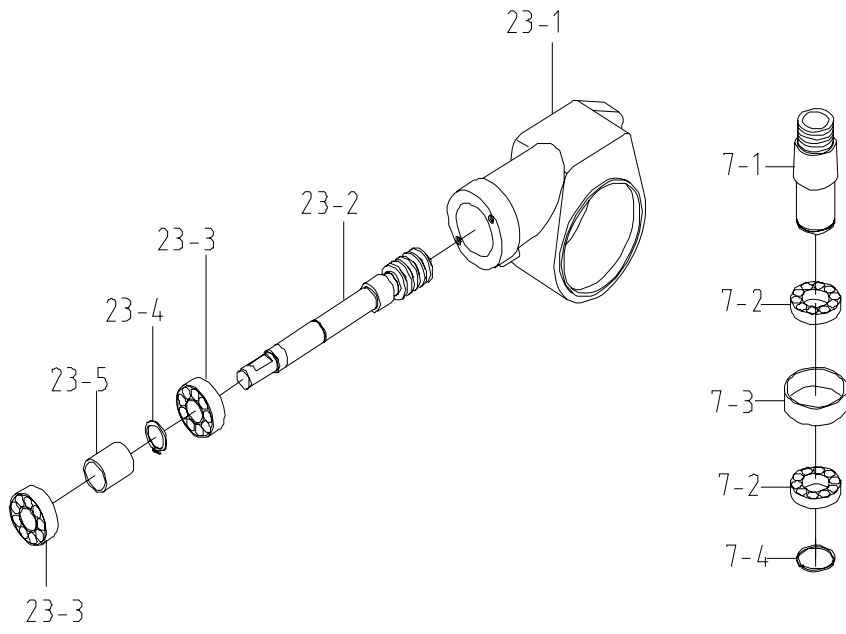

PARTS LIST
MODEL NO.31

CODE NO	PART NO	DESCRIPTION	SPECIFICATION	QTY	NOTE
1	6511	Head Body		1	
2	6101	Chuck Arbor Bolt	MT3 M10xP1.5	1	
2	6101-1	Chuck Arbor Bolt	MT3 M12xP1.75	1	
2	6101-2	Chuck Arbor Bolt	MT3 W3/8"-16	1	
2	6101-3	Chuck Arbor Bolt	MT3 W1/2"-12	1	
2	6101-4	Chuck Arbor Bolt	R8 W7/16"-20	1	
2	6101-5	Chuck Arbor Bolt	NT30 M12xP1.75	1	
3	6102B	Spindle Locknut		1	
4	6103A	Spindle Pulley		1	
5	6105	Outer Bearing Plate	φ 105x66x2.5t	1	
6	S701	Cross Round Head Screw	1/4"x1/2"L	3	
7	6106S	Spindle Taper Sleeve Asbly		1	
7-1	6106	Spindle Taper Sleeve		1	
7-2	CA6009ZZ	Ball Bearing (6009ZZ)	6009ZZ	2	
7-3	6108	Washer	φ 74x φ 68x22	1	
7-4	6123	Fixed Ring	φ 2x φ 41	1	
8	6109	C-Retainer Ring	φ 3x φ 80	1	
9	6112	Rubber Flange		1	
10	6513	Feed Base		1	
11	6116-2S	Pinion Asbly	MT3	1	
11	6116-3S	Pinion Asbly	MT3 Heat treatment	1	
11	6116-6S	Pinion Asbly	R8	1	
11	6116-2NS	Pinion Asbly	NT30	1	
11	6116-2SS	Pinion Asbly		1	Option
11-1	6114	Locknuts		2	
11-2	HI902	Washer	AW06 φ 30	1	
11-3	CA30206J	Taper Roller Bearing	E30206J	1	
11-4	6116-2	Rack Sleeve	MT3	1	
11-4	6116-3	Rack Sleeve	MT3 Heat treatment	1	
11-4	6116-6	Rack Sleeve	R8	1	
11-5	CA30207J	Taper Roller Bearing	30207J	1	
11-6	6117	Spindle Shaft	MT3	1	
11-6	6117-1	Spindle Shaft	MT3 Heat treatment	1	
11-6	6117-2	Spindle Shaft	R8	1	
11-6	6117-3	Spindle Shaft	NT30	1	
11-7	6119	Bearing Cap	MT3R8	1	
11-7	6119-1	Bearing Cap	NT30	1	
12	6168	Punch Key		1	
13	6121	Chuck Arbor	MT3 M10xP1.5	1	
13	6121-1	Chuck Arbor	MT3 M12xP1.75	1	
13	6121-2	Chuck Arbor	MT3 W3/8"-16	1	
13	6121-3	Chuck Arbor	MT3 W1/2"-12	1	
13	6121-4	Chuck Arbor	R8 W7/16"-20	1	

PARTS LIST
MODEL NO.31

CODE NO	PART NO	DESCRIPTION	SPECIFICATION	QTY	NOTE
13	6121-5	Chuck Arbor	R8 7/16"-20 JT3	1	
13	6121-7	Chuck Arbor	MT3 M12-B16	1	
13	6121-9	Chuck Arbor	MT3 M12 B18	1	
13	6121-10	Chuck Arbor	MT3 M10- B16	1	
13	6122-3	Chuck Arbor	NT30	1	
14	6120	Cutter Arbor	25.4 M10xP1.5	1	
14	6120-1	Cutter Arbor	25.4 M12xP1.75	1	
14	6120-2	Cutter Arbor	25.4 W3/8"-16	1	
14	6120-3	Cutter Arbor	25.4 W1/2"-12	1	
14	6120-4	Cutter Arbor	25.4 W7/16"-20	1	
14	6120-7	Cutter Arbor	27 M10xP1.75	1	
14	6120-9	Cutter Arbor	R8	1	
14	6120-10	Cutter Arbor	27 M10xP1.5	1	
14	6122C	Cutter Arbor	MT3 M10- ϕ 22	1	
14	6122D	Cutter Arbor	MT3 M12- ϕ 22	1	
14	6122	Cutter Arbor	NT30	1	
15	6554S	Graduated Rod Asbly		1	
16	6193	Nut		1	
17	S008	Hex. Head Screw	1/4"x2"L	1	
18	N003	Hex. Nut	1/4"	1	
19	6192	Position Set Bracket		1	
20	61106	Pinion Shaft		1	
21	S307	Flat Cross Head Screw	3/16"x1/2"L	1	
22	HK042	Key	7x7x20L	1	
23	61108S	Feed Cover Asbly		1	
23-1	61108	Bearing Cover		1	
23-2	6147	Worm Shaft		1	
23-3	CA6202ZZ	Ball Bearing (6202ZZ)	6202ZZ	2	
23-4	HCS04	C-Retaniner Ring	ϕ 15	1	
23-5	6135	Washer	ϕ 34x ϕ 27.5x30L	1	
24	S419	Hex. Socket Head Screw	5/16"x3/4"L	2	
25	61107	Worm Gear		1	
26	61115	Spring		1	
27	61110	Handle Base		1	
28	6138	Blade Adjustable Knob		1	
29	6139	Knob W/Shaft		3	
30	290086	Plastic Round Knob		3	
31	6145	Worm Cover		1	
32	S407	Cross Round Head Screw	3/16"x3/8"L	2	
33	6144S	Micro Adjusting Indicator Set	Metric	1	
33	6144-1S	Micro Adjusting Indicator Set	Inch	1	
35	6142-2AS	Handwheel Assembly		1	
37	61105S	Spring Base Set		1	

PARTS LIST
MODEL NO.31

CODE NO	PART NO	DESCRIPTION	SPECIFICATION	QTY	NOTE
38	MHP243	split pin	SSP5	1	
39	S732	Cross Round Head Screw	3/16"x3/4"L	3	
40	61103S	Spring Cover Asbly		1	
41	W202	Spring Washer	1/4"x1"x1.5t	1	
42	W005	Washer	1/4"	1	
43	W202	Spring Washer	1/4"x1"x1.5t	1	
44	S471	Hex. Socket Head Screw	1/4"x5/8L	1	
45	6559	Worm Shaft		1	
46	61114	Bushing		1	
47	61101S	Head Raise Bracket Asbly		1	
48	S404	Hex. Socket Head Screw	1/4"x3/4"L	4	
49	6158S	Head Handle Set		1	
51	6027-1S	Clamp Handle		1	
52	6126A	Fixed Tight Collar		1	
53	6125A	Fixed Tight Collar		1	
54	W002	Washer	1/2"x7/8"x2t	1	
55	6124	Handle Rod		1	
56	6127	Screw Key	3/8"-16UNC-38L	1	
57	N005	Hex. Nut	3/8"	1	
58	6162	Spring		1	
59	6563	Pin		1	
60	6179	Rubber Collar		1	
61	6552	Head Body Fix Bolt	5/8"-150L	2	
62	W019	Washer	5/8"x1-9/16"x3t	2	
63	N008	Hex. Nut	5/8"	2	
64	6550	Lock Handle		1	
65	6151	Thumb Screw	3/8"-16UNC	1	
65	6151B	Blade Adjustable Knob	3/8"-16UNC x30L	1	Option
66	6196S	Front Cover Plate Asbly		1	
67	S701	Cross Round Head Screw	1/4"x1/2"L	4	
68	61102	Limit Plate		1	
69	W032	Washer	1/8"	1	
70	S705	Cross Round Head Screw	1/8"x1/4"L	1	
71	6169E	Belt Cover	Palley Cover	1	
72	6169-3	Shelf		1	
74	6169B	Spindle Cover	Palley Cover	1	
75	HS801	Screw	3mm	2	
76	W017	Washer	5/16"	4	
77	S022	Hex. Head Screw	5/16"-18x3/4"L	4	
78	S701	Cross Round Head Screw	1/4"x1/2"L	2	For CE only
79	6557	Speed Chart		1	
80	6576B	Speed Change Inter Pulley Base		1	
81	N008	Hex. Nut	5/8"	1	

PARTS LIST
MODEL NO.31

CODE NO	PART NO	DESCRIPTION	SPECIFICATION	QTY	NOTE
82	W016	Washer	5/16"x28x3t	2	
83	S019	Hex. Head Screw	5/16"x1-1/2"L	2	
84	6173AS	Inter Pulley Asbly		1	
85	N008	Hex. Nut	5/8"	1	
86	6170DS	Motor Pulley Set		1	
88	BB033	V-Belt	B-33	1	
89	BB042	V-Belt	B-42	1	
90	6577	Wire Relief Retainer		1	
91	S017	Hex. Head Screw	5/16"-18x1"L	1	
92	6566	Motor Mount Plate		1	
93		Motor		1	
94	W017	Washer	5/16"	8	
95	S017	Hex. Head Screw	5/16"x1"L	4	
96	N007	Hex. Nut	5/16"	4	
97	S025	Hex. Head Screw	7/16"x3/4"L	2	
98	HK115	Key	8x7x45L	1	
99	6169-10	Guard Bracket(For CE Only)		1	For CE only
99	6169-7C	Guard Bracket(For CE Only)		1	Option
100	HS519	Cross Round Head Screw	M5x8L	2	For CE only
101	HS527	Cross Round Head Screw	M6x12L	2	For CE only
102	6169-11	Protective Plate(For CE Only)		1	For CE only
102	6169-11C	Protective Plate(For CE Only)		1	Option
113	6187	Chuck	1/2"-JT6	1	
113	6187-1	Chuck	1/2-B16	1	
114	6186	Milling Cutter	§ 25.4	1	
114	6186A	Milling Cutter	§ 25.4	1	
114	6186C	Milling Cutter	§ 22	1	
114	6186D	Milling Cutter	§ 27	1	
115	6638S	Micro Switch Bracket Set		1	For CE only
116		Switch		1	
124	690045S	Chuck Guard Asbly(For CE Only)		1	For CE only
124	690045AS	Chuck Guard Asbly(For CE Only)		1	For CE only (Option)
601	6628	Table	31	1	
601	6628-1	Table	31L	1	
602	6229	Fixed Block		2	
603	6230	Movable Fixed Ring		2	
604	S402	Hex. Socket Head Screw	1/4"x1/2"L	2	
605	HB111	Oil Ball	1/4"	5	
606	6601CS	Table Handle Wheel Set		3	
609	6620	Table Clutch	§ 17	1	
610	HP048	Cotter Pin	§ 5x40L	1	
611	6222	Left Flange	§ 17	1	
612	S414	Hex. Socket Head Screw	5/16"x1"L	6	

PARTS LIST
MODEL NO.31

CODE NO	PART NO	DESCRIPTION	SPECIFICATION	QTY	NOTE
613	6223S	Table Nut Set	31\31L Metric	1	
613	6223-1S	Table Nut Set	31\31L Inch	1	
616	6224S	Table Screw Asbly	31 Metric	1	
616	6224-1S	Table Screw Asbly	31 Inch	1	
616	6224-2S	Table Screw Asbly	31L Metric	1	
616	6224-3S	Table Screw Asbly	31L Inch	1	
617	6602-3	Link Screw		2	
618	61121	Limit Plate		2	
619	HH001	Rivet	§ 2	4	
620	6616	Center Base	31	1	
620	6616-1	Center Base	31L	1	
621	6217	Antidust Plate		1	
622	6218S	Antidust Plate Asbly		1	
623	6627	Gib Strip	31	1	
623	6627-1	Gib Strip	31L	1	
624	6607	Gib Strip		1	
625	6214	Movable Fixed Block		1	
626	S018	Hex. Head Screw	5/16"x1/2"L	4	
627	6212	Gib Strip Bolt		2	
628	6630	Bushing		4	
629	6213-1	Grip		2	
629	6213-2	Grip		2	
630	6151-1	T Screw		2	
630	6213	Thumb Screw		2	
631	S414	Hex. Socket Head Screw	5/16"x1"L	2	
632	S418	Hex. Socket Head Screw	5/16"x2-1/4"L	1	
633	6215S	Acme Nut Asbly	Metric	1	
633	6215-1S	Acme Nut Asbly	Inch	1	
634	6606	Swivel Base		1	
635	6605S	Acme Screw Asbly	Metric	1	
635	6605-1S	Acme Screw Asbly	Inch	1	
636	6608	Column Base		1	
636	6608-1	Column Base		1	
637	6610	Rack	600.5L	1	
637	6610-1	Rack	885.5L	1	
638	6611S	Column Head Asbly		1	
640	6609	Column Flange Ring		1	
641	S004	Hex. Head Screw	5/8"x2-1/2"L	4	
642	W206	Spring Washer	5/8"	4	
643	S419	Hex. Socket Head Screw	5/16"x3/4"L	2	
644	W205	Spring Washer	5/16"	3	
645	HB902	Plug	PT1/4"	2	
646	6241A	Vise		1	

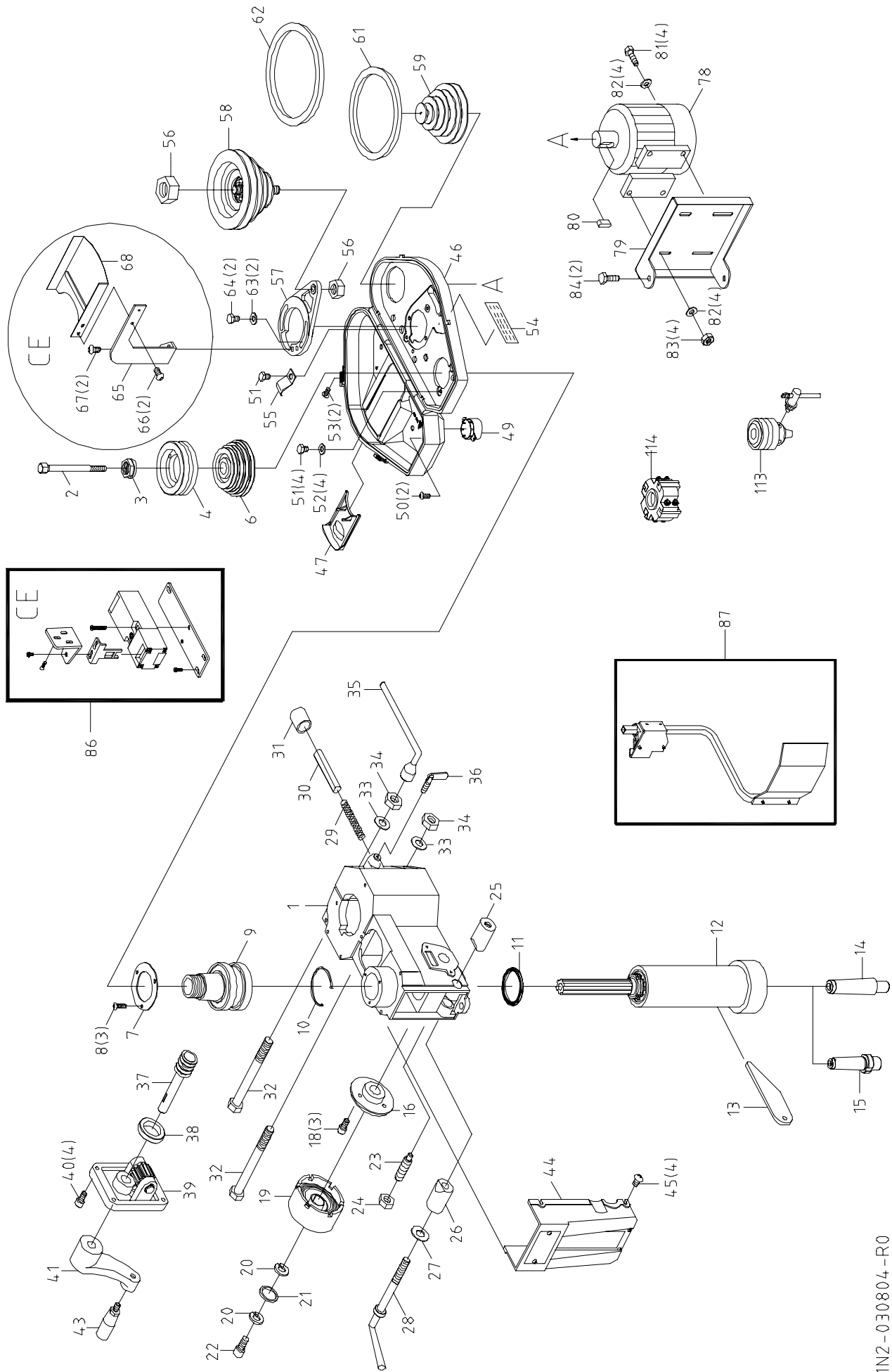

31N2-030804-R0

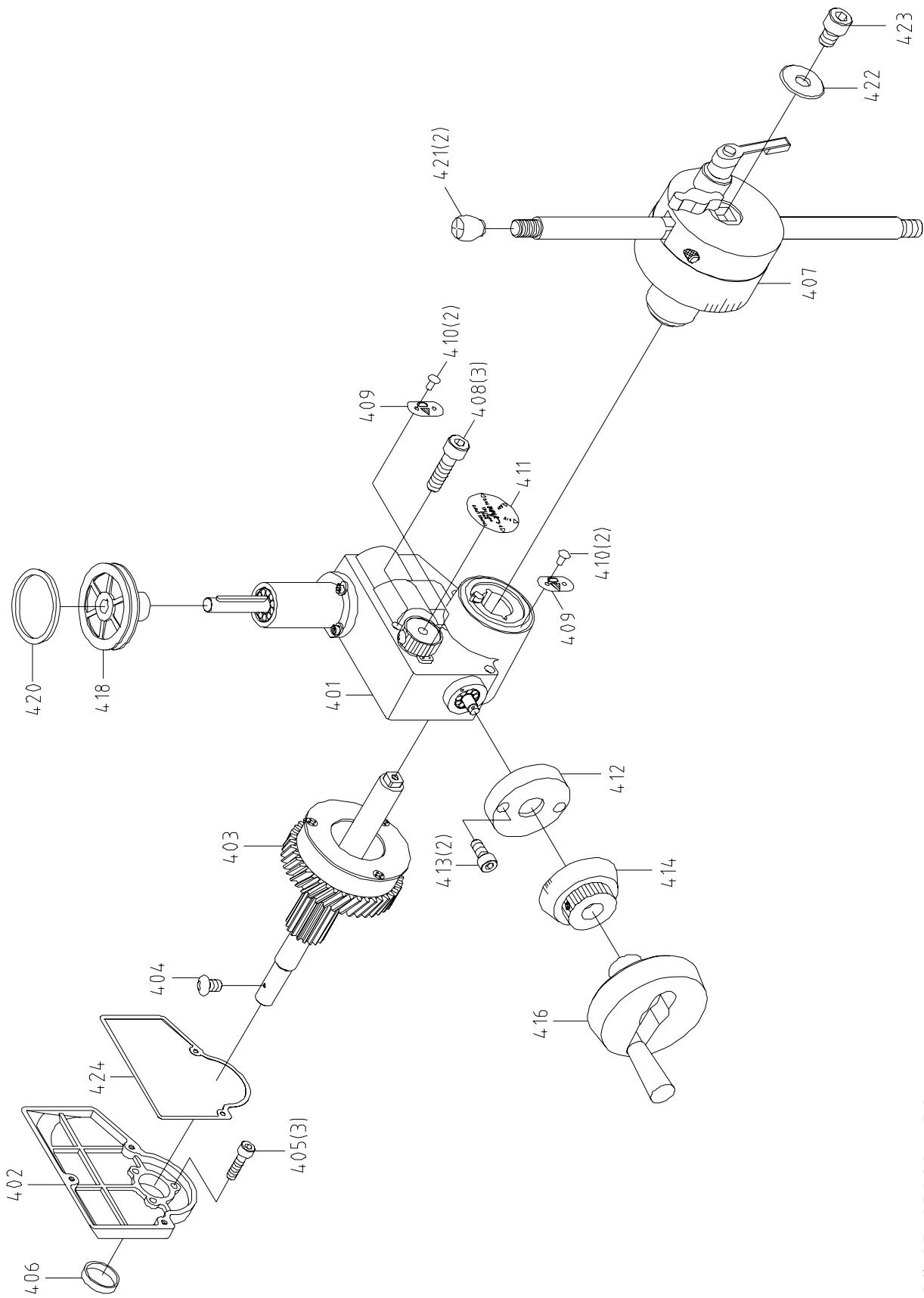

31N2F-030804-R0

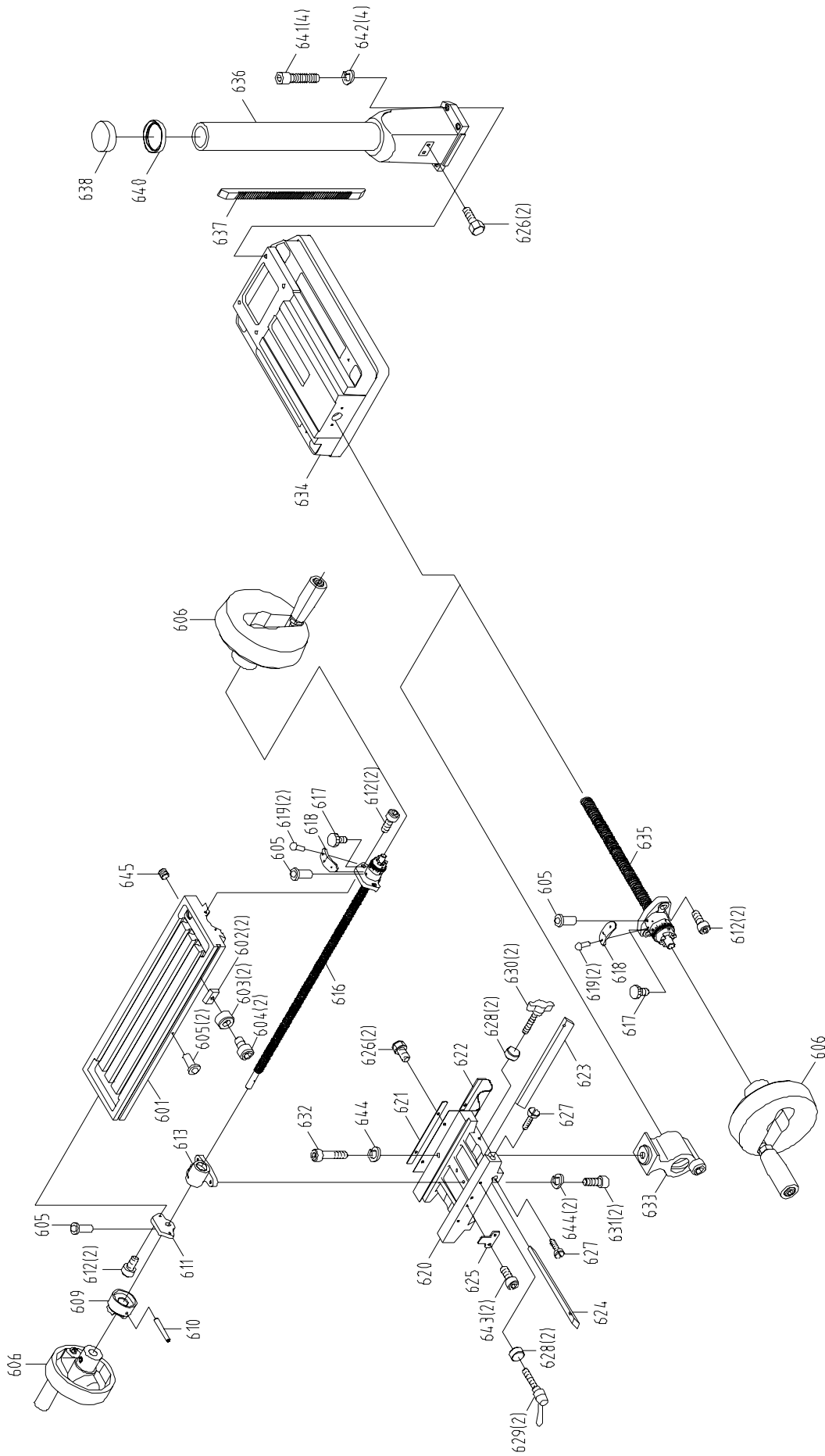

31TA

2006.07.20

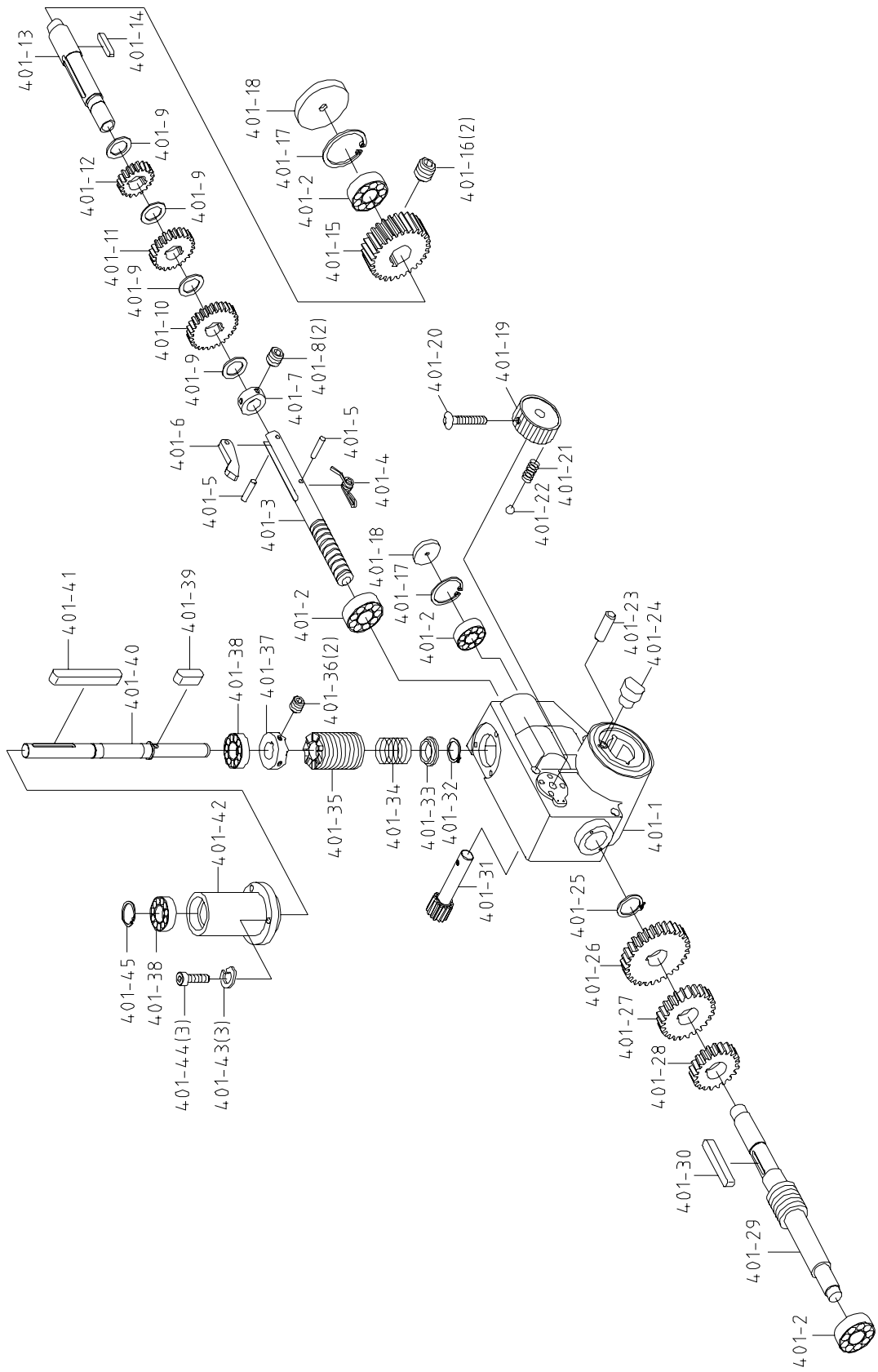

31N2F-030804-R0

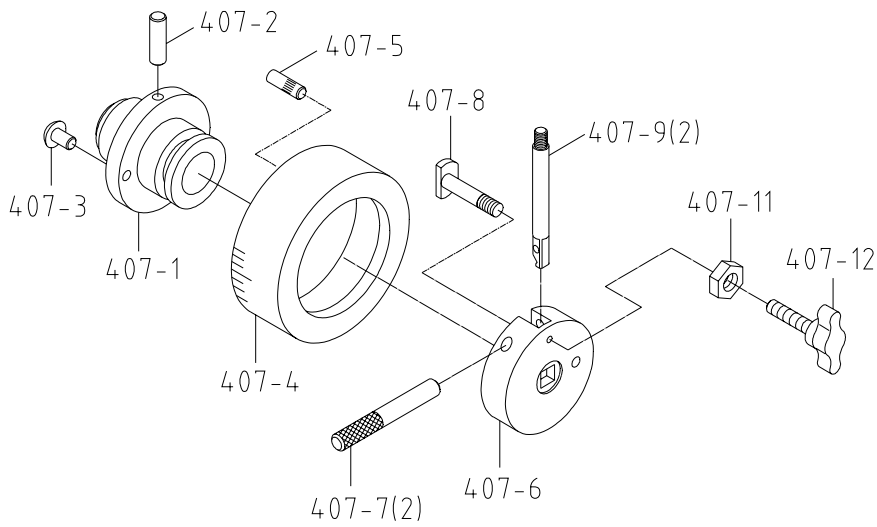
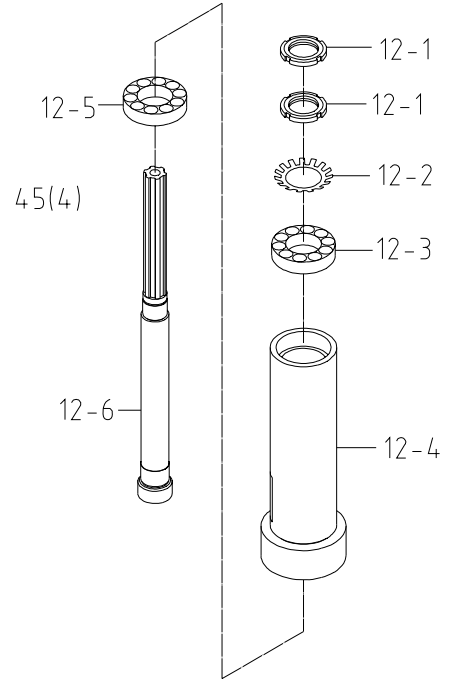
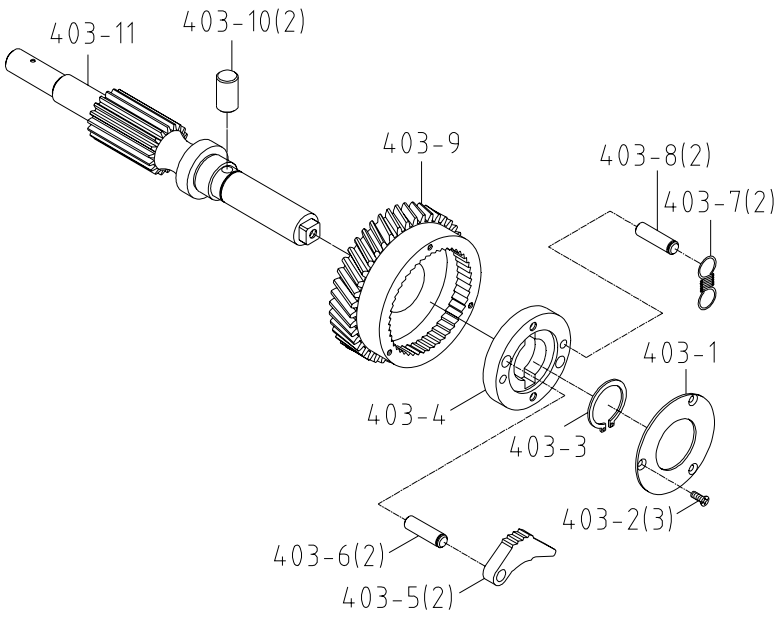
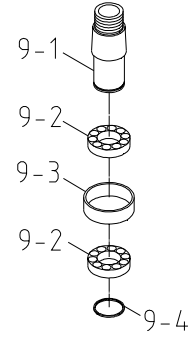
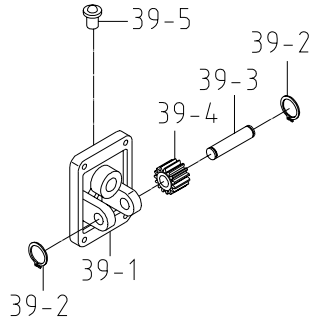

PARTS LIST
MODEL NO.31N2F

CODE NO	PART NO	DESCRIPTION	SPECIFICATION	QTY	NOTE
1	291045	Head Body		1	
2	6101	Chuck Arbor Bolt	MT3 M10xP1.5	1	
2	6101-1	Chuck Arbor Bolt	MT3 M12xP1.75	1	
2	6101-2	Chuck Arbor Bolt	MT3 W3/8"-16	1	
2	6101-3	Chuck Arbor Bolt	MT3 W1/2"-12	1	
2	6101-4	Chuck Arbor Bolt	R8 W7/16"-20	1	
2	6101-5	Chuck Arbor Bolt	NT30 M12xP1.75	1	
3	6102B	Spindle Locknut		1	
4	290111S	Main Pulley Set		1	
6	291052A	Spindle Pulley		1	
7	6105	Outer Bearing Plate	φ 105x66x2.5t	1	
8	S701	Cross Round Head Screw	1/4"x1/2"L	3	
9	6106S	Spindle Taper Sleeve Asbly		1	
9-1	6106	Spindle Taper Sleeve		1	
9-2	CA6009ZZ	Ball Bearing (6009ZZ)	6009ZZ	2	
9-3	6108	Washer	φ 74x φ 68x22	1	
9-4	6123	Fixed Ring	φ 2x φ 41	1	
10	6109	C-Retainer ring	φ 3x φ 80	1	
11	6112	Rubber Flange		1	
12	6116-2S	Pinion Asbly	MT3	1	
12	6116-3S	Pinion Asbly	MT3 Heat treatment	1	
12	6116-6S	Pinion Asbly	R8	1	
12	6116-2NS	Pinion Asbly	NT30	1	
12	6116-2SS	Pinion Asbly		1	Option
12-1	6114	Locknuts		2	
12-2	HI902	Washer	AW06 φ 30	1	
12-3	CA30206J	Taper Roller Bearing	E30206J	1	
12-4	6116-2	Rack Sleeve	MT3	1	
12-4	6116-3	Rack Sleeve	MT3 Heat treatment	1	
12-4	6116-6	Rack Sleeve	R8	1	
12-5	CA30207J	Taper Roller Bearing	30207J	1	
12-6	6117	Spindle Shaft	MT3	1	
12-6	6117-1	Spindle Shaft	MT3 Heat treatment	1	
12-6	6117-2	Spindle Shaft	R8	1	
12-6	6117-3	Spindle Shaft	NT30	1	
12-7	6119	Bearing Cap	MT3R8	1	
12-7	6119-1	Bearing Cap	NT30	1	
13	6168	Punch Key		1	
14	6121	Chuck Arbor	MT3 M10xP1.5	1	
14	6121-1	Chuck Arbor	MT3 M12xP1.75	1	
14	6121-2	Chuck Arbor	MT3 W3/8"-16	1	
14	6121-3	Chuck Arbor	MT3 W1/2"-12	1	
14	6121-4	Chuck Arbor	R8 W7/16"-20	1	

PARTS LIST
MODEL NO.31N2F

CODE NO	PART NO	DESCRIPTION	SPECIFICATION	QTY	NOTE
14	6121-5	Chuck Arbor	R8 7/16"-20 JT3	1	
14	6121-7	Chuck Arbor	MT3 M12-B16	1	
14	6121-9	Chuck Arbor	MT3 M12 B18	1	
14	6121-10	Chuck Arbor	MT3 M10- B16	1	
14	6122-3	Chuck Arbor	NT30	1	
15	6120	Cutter Arbor	25.4 M10xP1.5	1	
15	6120-1	Cutter Arbor	25.4 M12xP1.75	1	
15	6120-2	Cutter Arbor	25.4 W3/8"-16	1	
15	6120-3	Cutter Arbor	25.4 W1/2"-12	1	
15	6120-4	Cutter Arbor	25.4 W7/16"-20	1	
15	6120-7	Cutter Arbor	27 M10xP1.75	1	
15	6120-9	Cutter Arbor	R8	1	
15	6120-10	Cutter Arbor	27 M10xP1.5	1	
15	6122C	Cutter Arbor	MT3 M10- § 22	1	
15	6122D	Cutter Arbor	MT3 M12- § 22	1	
15	6122	Cutter Arbor	NT30	1	
16	61105S	Spring Base Set		1	
18	S732	Cross Round Head Screw	3/16"x3/4"L	3	
19	61103S	Spring Cover Asbly		1	
20	W202	Spring Washer	1/4"x1"x1.5t	2	
21	W005	Washer	1/4"	1	
22	S471	Hex. Socket Head Screw	1/4"x5/8L	1	
23	6127	Screw Key	3/8"-16UNC-38L	1	
24	N005	Hex. Nut	3/8"	1	
25	6126A	Fixed Tight Collar		1	
26	6125A	Fixed Tight Collar		1	
27	W002	Washer	1/2"x7/8"x2t	1	
28	6124	Handle Rod		1	
29	6162	Spring		1	
30	6563	Pin		1	
31	6179	Rubber Collar		1	
32	6552	Head Body Fix Bolt	5/8"-150L	2	
33	W019	Washer	5/8"x1-9/16"x3t	2	
34	N008	Hex. Nut	5/8"	2	
35	6550	Lock Handle		1	
36	6151	Thumb Screw	3/8"-16UNC	1	
37	6559	Worm Shaft		1	
38	61114	Bushing		1	
39	61101S	Head Raise Bracket Asbly		1	
39-1	61101	Head Raise Bracket		1	
39-2	HCS03	C-Retaniner Ring	§ 14	2	
39-3	6561	Worm Shaft	§ 9/16"x64.3L	1	
39-4	6160	Worm Gear		1	

PARTS LIST
MODEL NO.31N2F

CODE NO	PART NO	DESCRIPTION	SPECIFICATION	QTY	NOTE
39-5	HB111	Oil Ball	1/4"	1	
40	S404	Hex. Socket Head Screw	1/4"x3/4"L	4	
41	6158S	Head Handle Set		1	
43	6027-1S	Head Asbly		1	
44	6196SA	Front Cover Plate Asbly		1	
45	S701	Cross Round Head Screw	1/4"x1/2"L	4	
46	6169E	Belt Cover	Palley Cover	1	
47	6169-3	Shelf		1	
49	6169B	Spindle Cover	Palley Cover	1	
50	HS801	Screw	M3X5L	2	
51	S022	Hex. Head Screw	5/16"-18x3/4"L	5	
52	W017	Washer	5/16"X18Xt1.5	4	
53	S701	Cross Round Head Screw	1/4"x1/2"L	2	For CE only
54	6557	Speed Chart		1	
55	6577	Wire Relief Retainer		1	
56	N008	Hex. Nut	5/8"	2	
57	6576B	Speed Change Inter Pulley Base Palley Cover		1	
58	6173AS	Inter Pulley Asbly		1	
59	6170DS	Motor Pulley Set		1	
61	BB033	V-Belt	B-33	1	
62	BB042	V-Belt	B-42	1	
63	W016	Washer	5/16"	2	
64	S019	Hex. Head Screw	5/16"x1-1/2"L	2	
65	6169-10	Guard Bracket(For CE Only)		1	For CE only
65	6169-7C	Guard Bracket(For CE Only)		1	Option
66	HS519	Cross Round Head Screw	M5x8L	2	For CE only
67	HS528	Cross Round Head Screw	M6x12L	2	For CE only
68	6169-11	Protective Plate(For CE Only)		1	For CE only
68	6169-11C	Protective Plate(For CE Only)		1	Option
78		Motor		1	
79	6566	Motor Mount Plate		1	
80	HK115	Key	8x7x45L	1	
81	S017	Hex. Head Screw	5/16"x1"L	4	
82	W015	Washer	5/16"	8	
83	N007	Hex. Nut	5/16"	4	
84	S025	Hex. Head Screw	7/16"x3/4"L	2	
86	6638S	Micro Switch Bracket Set		1	For CE only
87	690045S	Chuck Guard Asbly(For CE Only)		1	For CE only
87	690045AS	Chuck Guard Asbly(For CE Only)		1	For CE only (Option)
113	6187	Chuck	1/2"-JT6	1	
113	6187-1	Chuck	1/2-B16	1	
114	6186A	Milling Cutter	§ 25.4	1	
114	6186C	Milling Cutter	§ 22	1	

PARTS LIST
MODEL NO.31N2F

CODE NO	PART NO	DESCRIPTION	SPECIFICATION	QTY	NOTE
115		Switch		1	
401	291022AS	Gear Box Assembly		1	
401-1	291022B	Gear Box		1	
401-2	CA6003ZZ	Bearing	6003ZZ	4	
401-3	2450082A	Change Gear Lever		1	
401-4	2450084B	Twisted Spring		1	
401-5	HP006	Pin	φ 3x10L	2	
401-6	2450083A	Speed-Changing Key		1	
401-7	2450089A	Bushing Bracket		1	
401-8	HS421	Hex. Socker Headless Screw	M6x6L	2	
401-9	2450074A	Bushing		4	
401-10	2450072A	Gear		1	
401-11	2450071A	Gear		1	
401-12	2450070A	Gear		1	
401-13	291026A	Worm Shaft		1	
401-14	HK009	Key	5x5x25L	1	
401-15	291047	Worm Gear		1	
401-16	HS421	Hex. Socker Headless Screw	M6x6L	2	
401-17	HCR04	C-Retainer ring	R35	2	
401-18	2450014	Cover		2	
401-19	2450079	Speed Lever		1	
401-20	HS512	Cross Round Head Screw	M4x0.7x25L	1	
401-21	290089	Spring		1	
401-22	HB001	Steel Ball	φ 8 or 5/16"	1	
401-23	2450051	Pin		1	
401-24	2450020	Release Block		1	
401-25	HCS08	C-Retainer ring	S19	1	
401-26	2450077A	Gear		1	
401-27	2450076A	Gear		1	
401-28	2450075A	Gear		1	
401-29	291028A	Transmission Worm Shaft		1	
401-30	HK011	Key	5x5x32L	1	
401-31	291027A	Gear Shaft		1	
401-32	HCS04	C-Retainer ring	S15	1	
401-33	2450057	Bushing		1	
401-34	2450054	Spring		1	
401-35	291046	Worm Shaft		1	
401-36	HS421	Hex. Socker Headless Screw	M6x6L	2	
401-37	291050	Clutch Block		1	
401-38	CA6003ZZ	Bearing	6003ZZ	2	
401-39	HK006	Key	5x5x10L	1	
401-40	291023A	Worm Shaft		1	
401-41	HK013	Key	5x5x45L	1	

PARTS LIST
MODEL NO.31N2F

CODE NO	PART NO	DESCRIPTION	SPECIFICATION	QTY	NOTE
401-42	291024A	Worm Base		1	
401-43	W202	Spring Washer	1/4"	3	
401-44	S404	Hex. Socket Head Screw	1/4"x3/4"L	3	
401-45	HCS06	C-Retainer ring	S17	1	
402	291032A	Gear Box Cover		1	
403	291029AS	Pinion Shaft Assembly		1	
403-1	2450048	Worm Gear Cover		1	
403-2	HS605	Flat Cross Head Screw	M4x4L	3	
403-3	HCS13	C-Retainer ring	S25	1	
403-4	2450024	Clutch Key Base		1	
403-5	2450026	Clutch Key		2	
403-6	2450025	Clutch Key Pin		2	
403-7	2450028	Spring		2	
403-8	2450027	Spring Pin		2	
403-9	2450023	Worm Gear		1	
403-10	2450022	Key		2	
403-11	291029A	Pinion Shaft		1	
404	S303	Flat Cross Head Screw	3/16"x3/8"L	1	
405	S416	Hex. Socket Head Screw	5/16"x1-1/4"L	3	
406	291049	Bearing Spacer		1	
407	291030AS	Clutch Bushing Assembly	Metric	1	
407	291030BS	Clutch Bushing Assembly	Inch	1	
407-1	291030A	Clutch Bushing		1	
407-2	2450030	Bushing Pin		1	
407-3	2450031	Bushing Stop		1	
407-4	2450032A	Scale Base	Inch	1	
407-4	2450032B	Scale Base	Metric	1	
407-5	HP016	Pin	ϕ 5	1	
407-6	2450037	Handle Body		1	
407-7	2450039	Handle Rod Pin		2	
407-8	2450033	Scale Base Set Screw		1	
407-9	2450038	Knob W/Shaft		2	
407-10	2450063	Graduated Base Fixed Grip		1	
407-11	N007	Hex. Nut	5/16"	1	
407-12	2450098	T Screw	5/16"x3/4"L	1	
408	S474	Hex. Socket Head Screw	5/16"x3-1/2"L	3	
409	2450060	Scale		2	
410	HH001	Rivet	ϕ 2x4L	4	
411	291064	Speed Scale	Metric	1	
411	291064A	Speed Scale	Inch	1	
412	6145	Worm Cover		1	
413	S708	Cross Round Head Screw	3/16"x3/8"L	2	
414	291051S	Micro Adjusting Indicator Set	Metric	1	

PARTS LIST
MODEL NO.31N2F

CODE NO	PART NO	DESCRIPTION	SPECIFICATION	QTY	NOTE
414	291051AS	Micro Adjusting Indicator Set	Inch	1	
416	6142BS	Handwheel Assembly		1	
418	290110S	Sub-Pulley Set		1	
420	290114	Round Belt	§ 8x679	1	
421	290086	Plastic Round Knob		2	
422	HW016	Washer	5/16"x23x2t	1	
423	HS241	Hex. Socket Head Screw	M8x12L	1	
424	291057	Rubber Plate		1	
601	6628	Table	31	1	
601	6628-1	Table	31L	1	
602	6229	Fixed Block		2	
603	6230	Movable Fixed Ring		2	
604	S402	Hex. Socket Head Screw	1/4"x1/2"L	2	
605	HB111	Oil Ball	1/4"	5	
606	6601CS	Table Handle Wheel Set		3	
609	6620	Table Clutch	§ 17	1	
610	HP048	Cotter Pin	§ 5x40L	1	
611	6222	Left Flange	§ 17	1	
612	S414	Hex. Socket Head Screw	5/16"x1"L	6	
613	6223S	Table Nut Set	31\31L Metric	1	
613	6223-1S	Table Nut Set	31\31L Inch	1	
616	6224S	Table Screw Asbly	31 Metric	1	
616	6224-1S	Table Screw Asbly	31 Inch	1	
616	6224-2S	Table Screw Asbly	31L Metric	1	
616	6224-3S	Table Screw Asbly	31L Inch	1	
617	6602-3	Link Screw		2	
618	61121	Limit Plate		2	
619	HH001	Rivet	§ 2	4	
620	6616	Center Base	31	1	
620	6616-1	Center Base	31L	1	
621	6217	Antidust Plate		1	
622	6218S	Antidust Plate Asbly		1	
623	6627	Gib Strip	31	1	
623	6627-1	Gib Strip	31L	1	
624	6607	Gib Strip		1	
625	6214	Movable Fixed Block		1	
626	S018	Hex. Head Screw	5/16"x1/2"L	4	
627	6212	Gib Strip Bolt		2	
628	6630	Bushing		4	
629	6213-1	Grip		2	
629	6213-2	Grip		2	
630	6151-1	T Screw		2	
630	6213	Thumb Screw		2	

PARTS LIST
MODEL NO.31N2F

CODE NO	PART NO	DESCRIPTION	SPECIFICATION	QTY	NOTE
631	S414	Hex. Socket Head Screw	5/16"x1"L	2	
632	S418	Hex. Socket Head Screw	5/16"x2-1/4"L	1	
633	6215S	Acme Nut Asbly	Metric	1	
633	6215-1S	Acme Nut Asbly	Inch	1	
634	6606	Swivel Base		1	
635	6605S	Acme Screw Asbly	Metric	1	
635	6605-1S	Acme Screw Asbly	Inch	1	
636	6608	Column Base		1	
636	6608-1	Column Base		1	
637	6610	Rack	600.5L	1	
637	6610-1	Rack	885.5L	1	
638	6611S	Column Head Asbly		1	
640	6609	Column Flange Ring		1	
641	S004	Hex. Head Screw	5/8"x2-1/2"L	4	
642	W206	Spring Washer	5/8"	4	
643	S419	Hex. Socket Head Screw	5/16"x3/4"L	2	
644	W205	Spring Washer	5/16"	3	
645	HB902	Plug	PT1/4"	2	
646	6241A	Vise		1	

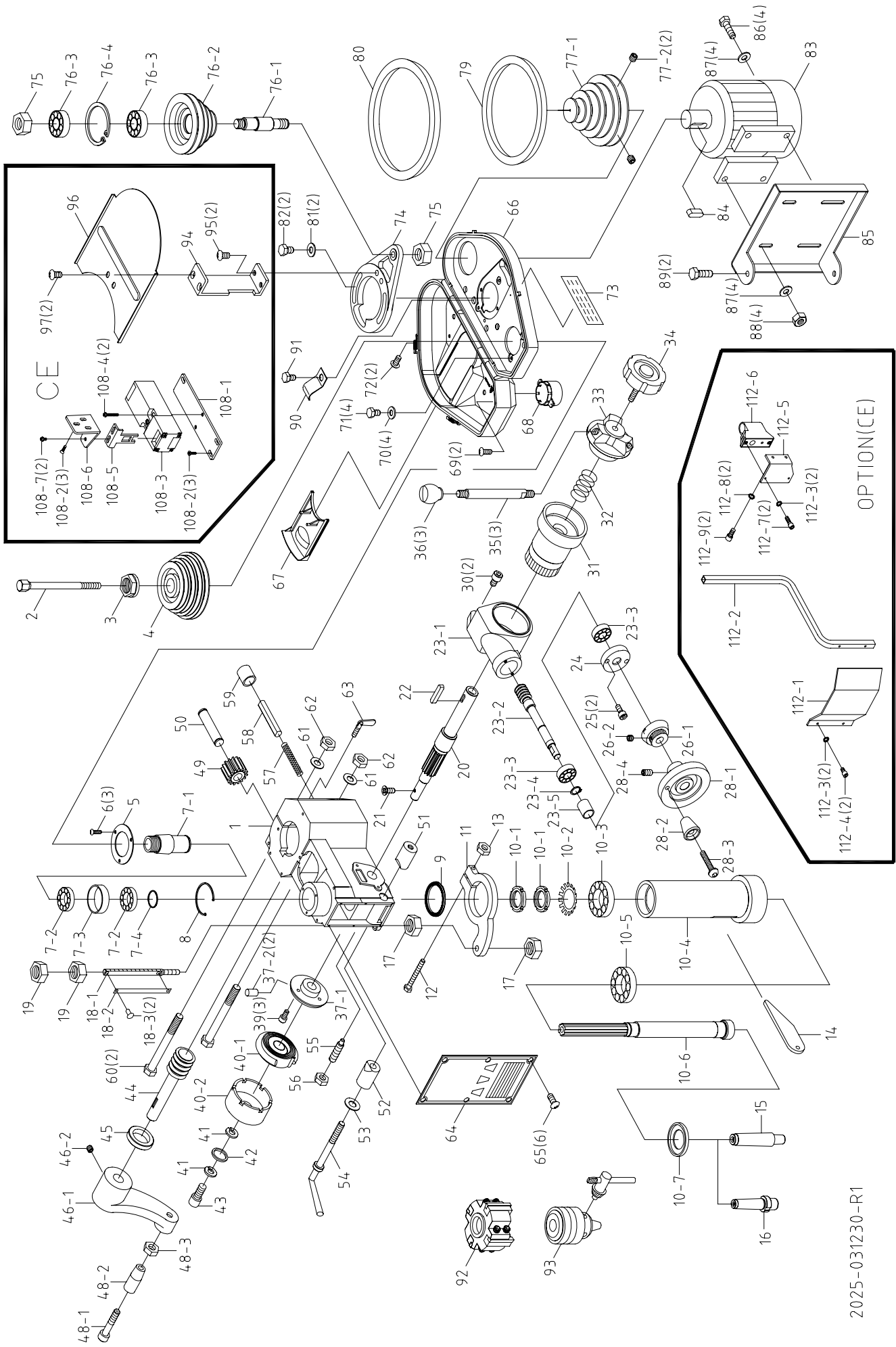

2025-031230-R1

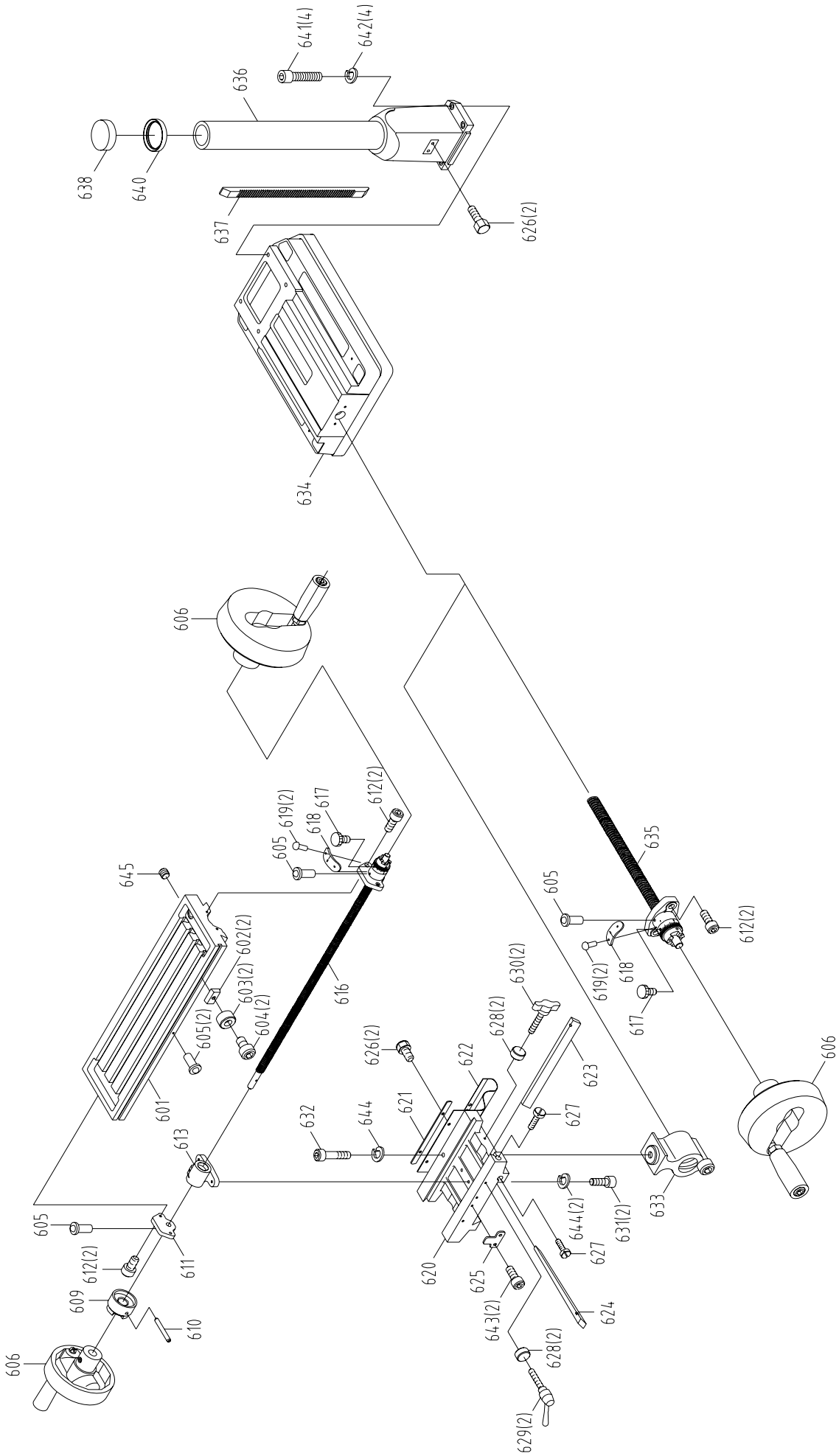

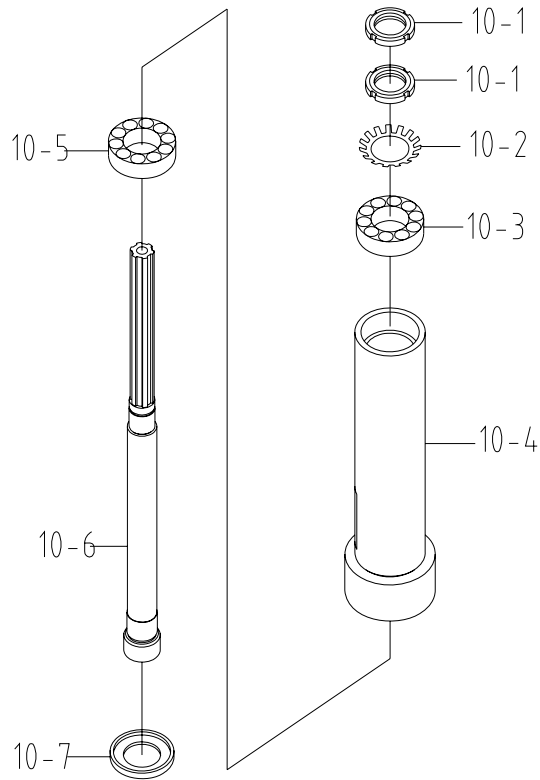
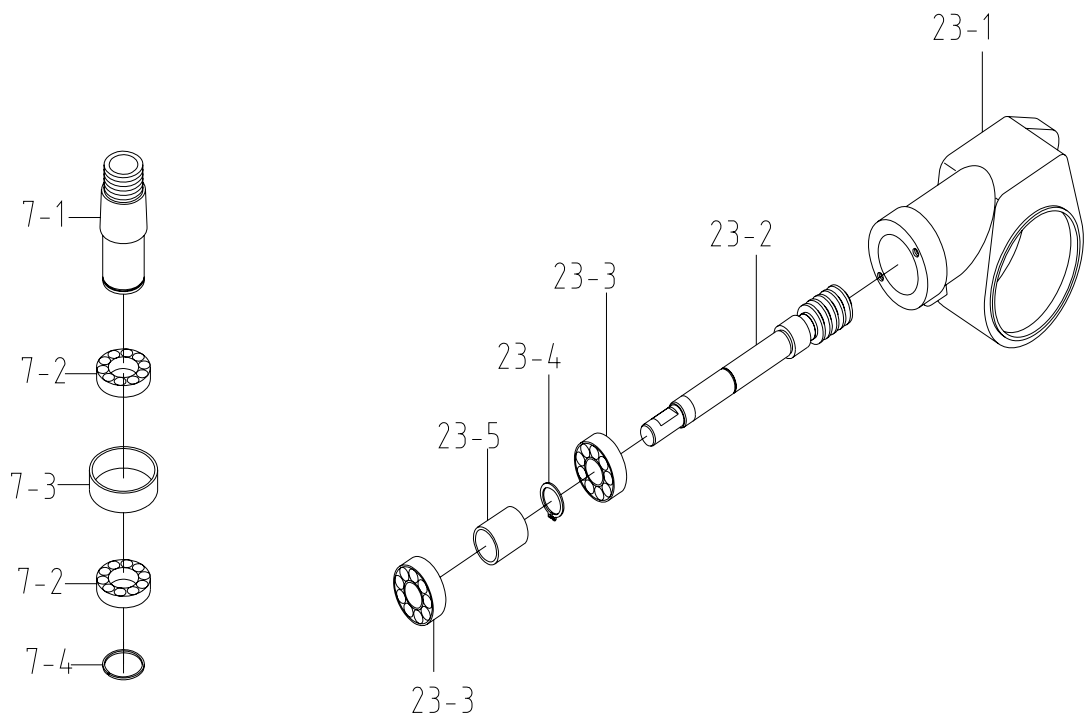

PARTS LIST
MODEL NO.25

CODE NO	PART NO	DESCRIPTION	SPECIFICATION	QTY	NOTE
1	7111	Head Body		1	
2	7101	Chuck Arbor Bolt	MT3 M10xP1.5	1	
2	7101-1	Chuck Arbor Bolt	M12xP1.75	1	
2	7101-2	Chuck Arbor Bolt	W3/8"-16	1	
2	7101-3	Chuck Arbor Bolt	W1/2"-12	1	
2	7101-4	Chuck Arbor Bolt	W7/16"-20	1	
3	7102B	Spindle Locknut		1	
4	7103B	Spindle Pulley		1	
5	7105	Outer Bearing Plate	φ 84x50x2.8t	1	
6	S701	Cross Round Head Screw	1/4"x1/2"L	3	
7	7106S	Spindle Taper Sleeve Set		1	
7-1	7106	Spindle Taper Sleeve		1	
7-2	CA6007ZZ	Ball Bearing (6007ZZ)	6007ZZ	2	
7-3	7108	Washer	φ 60x φ 55x16	1	
7-4	7123	Retainer Ring		1	
8	7109	C-Retainer ring	φ 3x φ 61	1	
9	7112	Rubber Flange		1	
10	7116S	Rack Sleeve Set	MT3	1	
10	7116-2S	Rack Sleeve Set	R8	1	
10	7116BS	Rack Sleeve Set	NT30 Heat treatment	1	
10	7116SS	Rack Sleeve Set	MT3	1	Option
10-1	7114	Locknuts		2	
10-2	HI901	Washer	φ 25.4	1	
10-3	CA30205J	Taper Roller Bearing (30205J)	E30205J	1	
10-4	7116	Rack Sleeve	MT3	1	
10-4	7116-2	Rack Sleeve	R8	1	
10-5	CA30206J	Taper Roller Bearing (30206J)	E30206J	1	
10-6	7117	Spindle Shaft	MT3	1	
10-6	7117-2	Spindle Shaft	R8	1	
10-6	7117-3	Spindle Shaft	R8 Heat treatment	1	
10-7	7119	Bearing Cap	MT3R8	1	
11	7113	Feed Base		1	
12	S008	Hex. Head Screw	1/4"x2"L	1	
13	N003	Hex. Nut	1/4"	1	
14	6168	Punch Key		1	
15	6121	Chuck Arbor	MT3 M10xP1.5	1	
15	6121-1	Chuck Arbor	MT3 M12xP1.75	1	
15	6121-2	Chuck Arbor	MT3 W3/8"-16	1	
15	6121-3	Chuck Arbor	MT3 W1/2"-12	1	
15	6121-4	Chuck Arbor	R8 W7/16"-20	1	
15	6121-5	Chuck Arbor	R8 7/16"-20 JT3	1	
15	6121-7	Chuck Arbor	MT3 M12-B16	1	
15	6122-3	Chuck Arbor	NT30	1	

PARTS LIST
MODEL NO.25

CODE NO	PART NO	DESCRIPTION	SPECIFICATION	QTY	NOTE
16	7120	Cutter Arbor	MT3 M10xP1.5	1	
16	7120-1	Cutter Arbor	MT3 M12- ϕ 22	1	
16	7120-2	Cutter Arbor	MT3 W3/8"-16	1	
16	7120-3	Cutter Arbor	MT3 W1/2"-12	1	
16	7120-4	Cutter Arbor	R8 W7/16"-20	1	
17	N005	Hex. Nut	3/8"	2	
18	7154S	Granduated Rod Set		1	
19	N002	Hex. Nut	1/2"	2	
20	71106	Pinion Shaft		1	
21	S307	Flat Cross Head Screw	3/16"x1/2"L	1	
22	HK030	Key	6x6x45L	1	
23	61108S	Feed Cover Set		1	
23-1	61108	Feed Cover		1	
23-2	6147	Worm Shaft		1	
23-3	CA6202ZZ	Ball Bearing (6202ZZ)		2	
23-4	HCS04	C-Retaniner Ring	ϕ 15	1	
23-5	6135	Washer		1	
24	6145	Worm Cover		1	
25	S708	Cross Round Head Screw	3/16"x3/8"L	2	
26	6144S	Micro Adjusting Indicator Set	Metric	1	
26	6144-1S	Micro Adjusting Indicator Set	Inch	1	
28	6142-2AS	Handwheel Assembly		1	
30	S419	Hex. Socket Head Screw	5/16"x3/4"L	2	
31	61107	Worm Gear		1	
32	61115	Spring		1	
33	61110	Up-Down Handle		1	
34	6138	Blade Adjustable Knob		1	
35	6139	Knob W/Shaft		3	
36	290086	Plastic Round Knob		3	
37	61105S	Spring Base Set		1	
39	S732	Cross Round Head Screw	3/16"x3/4"L	3	
40	61103S	Spring&Spring Cover		1	
41	W202	Spring Washer	1/4"	2	
42	W005	Washer	1/4"	1	
43	S471	Hex. Socket Head Screw	1/4"x5/8L	1	
44	7159	Worm Shaft		1	
45	71114	Bushing		1	
46	7158S	Head Handle Set		1	
48	6027-1S	Knob		1	
49	6160	Worm Gear		1	
50	7161	Worm Shaft		1	
51	7126	Fixed Tight Collar		1	
52	7125	Fixed Tight Collar		1	

PARTS LIST
MODEL NO.25

CODE NO	PART NO	DESCRIPTION	SPECIFICATION	QTY	NOTE
53	W002	Washer	1/2"x7/8"x2t	1	
54	7124	Handle Rod		1	
55	7127	Screw Key		1	
56	N005	Hex. Nut	3/8"	1	
57	6162	Spring		1	
58	7163	Pin		1	
59	6179	Rubber Collar		1	
60	7152	Head Body Fix Bolt	1/2"-172L	2	
61	W001	Washer	1/2"x1-1/4"x3t	2	
62	N001	Hex. Nut	1/2"	2	
63	6151	Thumb Screw	3/8"-16UNC	1	
63	6151B	Blade Adjustable Knob	3/8"-16UNC x30L	1	Option
64		Name Plate		1	
65	S702	Cross Round Head Screw	1/4"x1/4"L	6	
66	7169A	Belt Cover		1	
67	6169-3	Shelf		1	
68	6169B	Spindle Cover		1	
69	HS801	Screw	3mm	2	
70	W005	Washer	1/4"	4	
71	S701	Cross Round Head Screw	1/4"x1/2"L	4	
72	HS528	Cross Round Head Screw	M6x12L	2	For CE only
73		Pulley Speed Chart		1	
74	7176B	Speed Change Inter Pulley Base		1	
75	N008	Hex. Nut	5/8"	2	
76	7173S	Inter Pulley Set		1	
77	7170DS	Motor Pulley Set		1	
78	HB111	Oil Ball	1/4"	1	
79	BA030	V-Belt	A30	1	
79	BG033	T-Belt	17310	1	
80	BA038	V-Belt	A38	1	
81	W017	Washer	5/16"	2	
82	S019	Hex. Head Screw	5/16"x1-1/2"L	2	
83		Motor		1	
84	HK029	Key	6X6X40L	1	
85	7166	Motor Mount Plate		1	
86	S017	Hex. Head Screw	5/16"x1"L	4	
87	W033	Washer	5/16"x27mmx2t	8	
88	N007	Hex. Nut	5/16"	4	
89	S011	Hex. Head Screw	3/8"x1/2"L	2	
90	6577	Wire Relief Retainer		1	
91	S701	Cross Round Head Screw	1/4"x1/2"L	1	
92	7186	Milling Cutter	§ 20	1	
92	7186A	Milling Cutter	§ 20	1	

PARTS LIST
MODEL NO.25

CODE NO	PART NO	DESCRIPTION	SPECIFICATION	QTY	NOTE
92	7186B	Milling Cutter	§ 22	1	
93	6187	Chuck	1/2"-JT6	1	
93	6187-1	Chuck	1/2"-B16	1	
94	7104-5	Protective Plate(For CE Only)		1	For CE only
95	HS527	Cross Round Head Screw	M6x10L	2	For CE only
96	7104-4	Protective Plate(For CE Only)		1	For CE only
96	7104B	Protective Plate(For CE Only)		1	Option
97	HS527	Cross Round Head Screw	M6x10L	2	For CE only
108	6638S	Micro Switch Bracket Set		1	For CE only
109		Switch		1	
124	690045S	Chuck Guard Asbly(For CE Only)		1	For CE only
124	690045AS	Chuck Guard Asbly(For CE Only)		1	For CE only (Option)
601	12228	Table		1	
602	6229	Fixed Block		2	
603	6230	Movable Fixed Ring		2	
604	S402	Hex. Socket Head Screw	1/4"x1/2"L	2	
605	HB111	Oil Ball	1/4"	5	
606	6601CS	Table Handle Wheel Set		3	
609	6620	Table Clutch	§ 17	1	
610	HP022	Pin	§ 5x38L	1	
611	6222	Left Flange		1	
612	S419	Hex. Socket Head Screw	5/16"x3/4"L	6	
613	6223S	Table Nut Set	Metric	1	
613	6223-1S	Table Nut Set	Inch	1	
616	12224S	Table Screw	Metric	1	
616	12224-1S	Table Screw	Inch	1	
617	6602-3	Link Screw		2	
618	61121	Limit Plate		2	
619	HH001	Rivet	§ 2	4	
620	12216	Center Base		1	
621	6217	Antidust Plate		1	
622	6218S	Antidust Plate		1	
623	7227	Gib Strip		1	
624	7207	Gib Strip		1	
625	6214	Movable Fixed Block		1	
626	S018	Hex. Head Screw	5/16"x1/2"L	4	
627	6212	Gib Strip Bolt		2	
628	6630	Bushing		4	
629	6213-1	Grip	AL	2	
629	6213-2	Grip		2	
630	6151-1	T Screw		2	
630	6213	Thumb Screw		2	
631	S414	Hex. Socket Head Screw	5/16"x1"L	2	

PARTS LIST
 MODEL NO.25

CODE NO	PART NO	DESCRIPTION	SPECIFICATION	QTY	NOTE
632	S418	Hex. Socket Head Screw	5/16"x2-1/4"L	1	
633	6215S	Acme Nut Set	Metric	1	
633	6215-1S	Acme Nut Set	Inch	1	
634	12206	Swivel Base		1	
635	7205S	Acme Screw Set	Metric	1	
635	7205-1S	Acme Screw Set	Inch	1	
636	7208	Column Base		1	
637	7210	Rack		1	
638	7211S	Column Head Set		1	
640	7209	Column Flange Ring		1	
641	S421	Hex. Socket Head Screw	7/16"x2"L	4	
642	W215	Spring Washer	7/16"	4	
643	S419	Hex. Socket Head Screw	5/16"x3/4"L	2	
644	W205	Spring Washer	5/16"	3	
645	HB902	Plug	PT1/4"	2	
646	6241A	Vise		1	

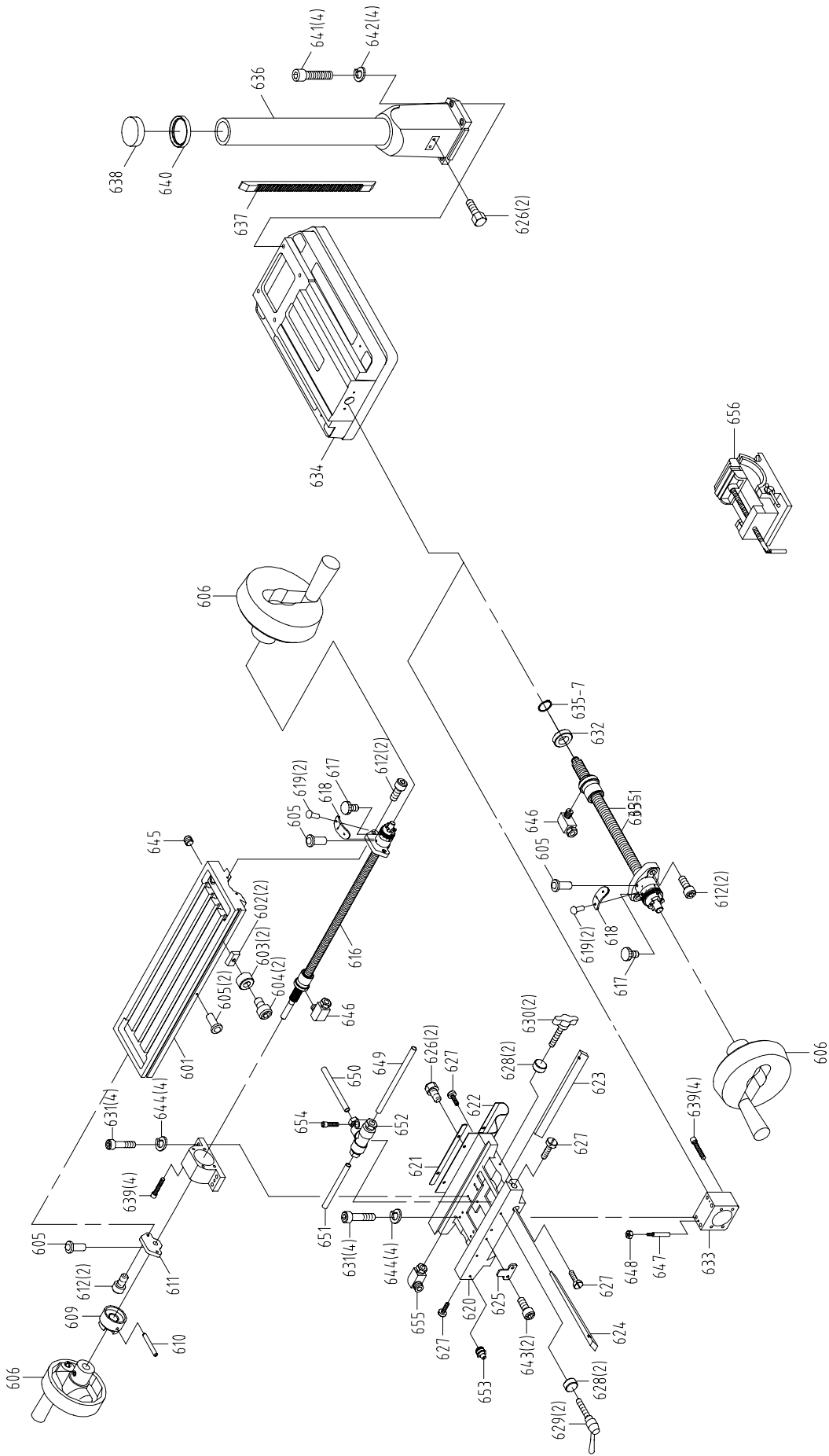

31BS
2010.09.02

PARTS LIST
MODEL NO. 31BS

CODE NO	PART NO	DESCRIPTION	SPECIFICATION	QTY	NOTE
601	6628	Table	31	1	
601	6628-1	Table	31L	1	
602	6229	Fixed Block		2	
603	6230	Movable Fixed Ring		2	
604	S402	Hex. Socket Head Screw	1/4"x1/2"L	2	
605	HB111	Oil Ball	1/4"	4	
606	6601CS	Table Handle Wheel Set		3	
609	6620	Table Clutch	φ 17	1	
610	HP048	Cotter Pin	φ 5x40L	1	
611	6222A	Left Flange	φ 17	1	
612	S414	Hex. Socket Head Screw	5/16"x1"L	6	
613	6642S	Table Nut Set		1	
616	6224AS	Table Screw Asbly	31	1	
616	242004S	Table Screw Asbly	31L	1	
617	6602-3	Link Screw		2	
618	61121	Limit Plate		2	
619	HH001	Rivet	φ 2	4	
620	6616G	Center Base	31 BS	1	
620	242002	Center Base	31L BS	1	
621	6217	Antidust Plate		1	
622	6218S	Antidust Plate Asbly		1	
623	6627	Gib Strip	31	1	
623	6627-1	Gib Strip	31L	1	
624	6607	Gib Strip		1	
625	6214	Movable Fixed Block		1	
626	S018	Hex. Head Screw	5/16"x1/2"L	4	
627	6212	Gib Strip Bolt		4	
628	6630	Washer		4	
629	6213-1	Grip		2	
629	6213-2	Grip		2	
630	6151-1	T Screw		2	
630	6213	Thumb Screw		2	
631	HS233	Hex. Socket Head Screw	M6x35L	8	
632	6643	Bushing		1	
633	6641	Acme Nut Base		1	
634	6606D	Swivel Base		1	
635	6605CS	Acme Screw Asbly		1	
636	6608	Column Base		1	
636	6608-1	Column Base		1	
637	6610	Rack	600.5L	1	
637	6610-1	Rack	885.5L	1	
638	6611S	Column Head Asbly		1	
640	6609	Column Flange Ring		1	
641	S004	Hex. Head Screw	5/8"x2-1/2"L	4	
642	W206	Spring Washer	5/8"	4	
643	S419	Hex. Socket Head Screw	5/16"x3/4"L	2	
644	W205	Spring Washer	5/16"	3	
645	HD103	Spring Washer	PT1/4"x3/8"L	1	
646	6661	Oil Hose Coupler	M8x90度 φ 6	2	
647	HP303	Pin	φ 6	2	
648	N003	Hex. Nut	1/4"	2	

PARTS LIST
 MODEL NO. 31BS

CODE NO	PART NO	DESCRIPTION	SPECIFICATION	QTY	NOTE
649	6656	Oil Hose	φ 6x230L	1	
650	6657	Oil Hose	φ 6x330L	1	
651	6658	Oil Hose	φ 6x140L	1	
652	6659	3 Way Connector	φ 6三孔	1	
653	HB501	Oil Ball	1/8"	1	
654	HS231	Hex. Socket Head Screw	M6x25L	1	
655	6660	Oil Hose Coupler	PT1/8x90度 φ 6	1	
656	6241A	Vise		1	

OPTIONAL ACCESSORIES (DRO)

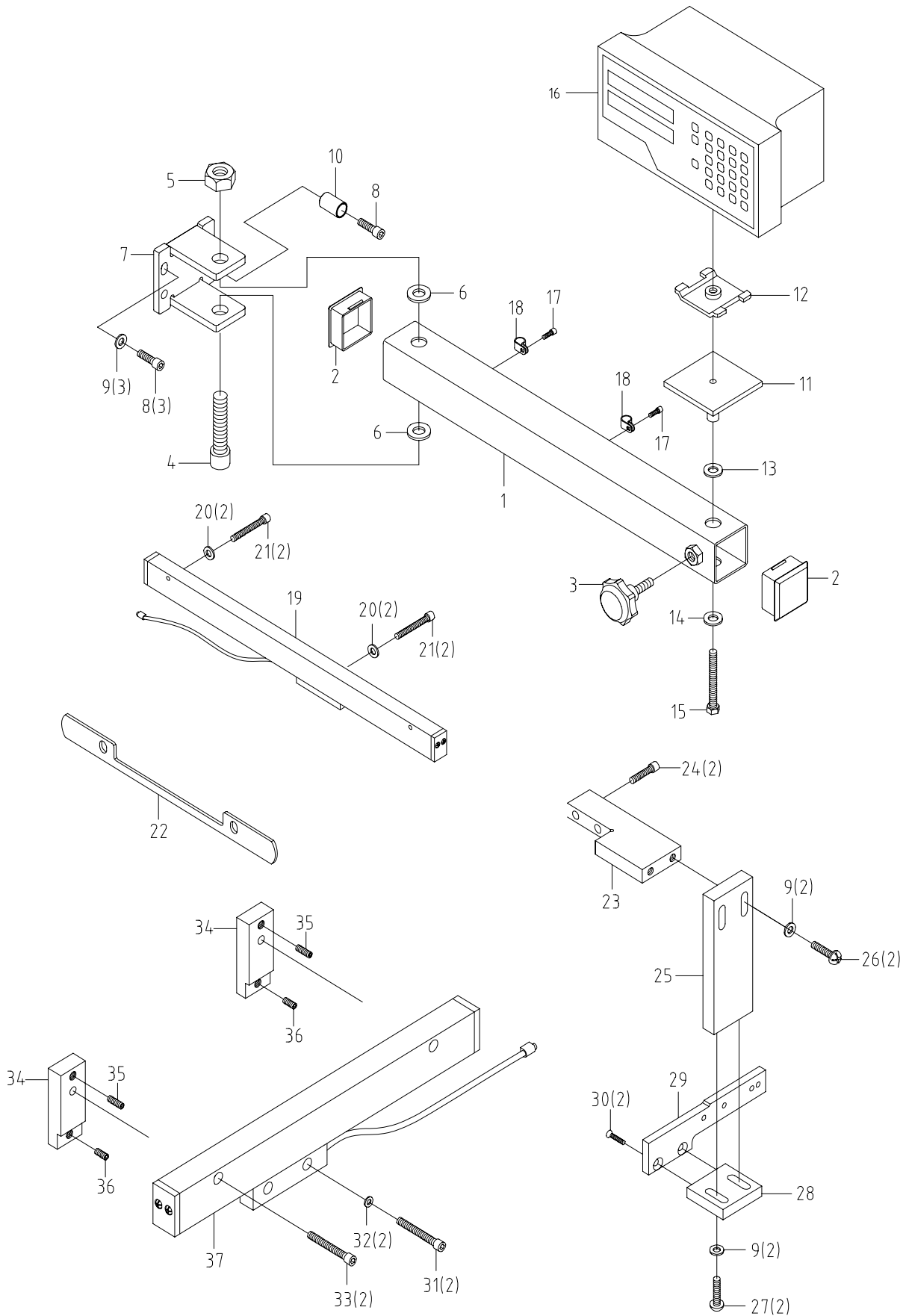

DRO-030902-R0

PARTS LIST

MODEL NO. DRO

CODE NO	PART NO	DESCRIPTION	SPECIFICATION	QTY	NOTE
1	670032	Radial Arm		1	
2	670044	Cover		2	
3	670046	Plum Screw	5/16"x1"L	1	
4	S482	Hex. Socket Head Screw	1/2"x2-3/4"L	1	
5	HB811	Nut	1/2"	1	
6	W035	Washer	ϕ 1/2"x ϕ 25x1.8t	2	
7	670033	Radial Arm Bracket		1	
8	S401	Hex. Socket Head Screw	1/4"x1"L	4	
9	W037	Washer	ϕ 7x ϕ 12x1.2t	7	
10	670045	Dramper		1	
11	670034	LCD rpm Monitor Base		1	
12	670035	Fixed Plate		1	
13	W036	Washer	ϕ 1/2"x ϕ 25x2t	1	
14	W038	Washer	ϕ 1/4"x ϕ 3/4"x1.5t	1	
15	HS041	Hex. Head Screw	M6x55L	1	
16	LS001	LCD rpm Monitor	MANVK-20	1	
17	HS202	Hex. Socket Head Screw	M3x10L	2	
18		Binder		2	
19	LS002	Scale	MKT47 (B)	1	
19	LS005	Scale	MKT52 (L)	1	
20	HW002	Washer	M4	4	
21	HS210	Hex. Socket Head Screw	M4x20L	4	
22	6217A	Antidust Plate		1	
23	670036A	Fixed Bracket		1	
24	S475	Hex. Socket Head Screw	1/4"x1-1/4"L	2	
25	670037B	Arm		1	
26	HT008	Round Head Screw	1/4"x1"L	2	
27	HT007	Round Head Screw	1/4"x3/4"L	2	
28	670040A	Plate		1	
29	670041A	Movable Base		1	
30	HD504	Hex. Socket Head Screw	3/16"x5/8"L	2	
31	HS210	Hex. Socket Head Screw	M4x20L	4	
32	HW002	Washer	M4	2	
33	HS215	Hex. Socket Head Screw	M4x45L	2	
34	670039D	Base		2	
35	S603	Hex. Socker Headless Screw	1/4"x3/4"L	2	
36	S604	Hex. Socker Headless Screw	1/4"x3/8"L	2	
37	LS003	Scale	MKT22	1	

MANUFACTURER:

ADDRESS:

SERIAL No.:

PLEASE WRITE DOWN THE SERIAL NO. ON THIS BLOCK FROM THE NAME
PLATE AFTER YOU RECEIVE THIS MACHINE.